

**One Binary Output (20 Amp Relay SPDT + Override)**

- **Contact Ratings:**

20 Amp Resistive @ 277 Vac	1110 VA Pilot Duty @ 277 Vac
20 Amp Magnetic Ballast @ 277 Vac	770 VA Pilot Duty @ 120 Vac
16 Amp Electronic Ballast @ 277 Vac (N/O)	2 HP @ 277 Vac
10 Amp Tungsten @ 120 Vac (N/O)	1 HP @ 120 Vac

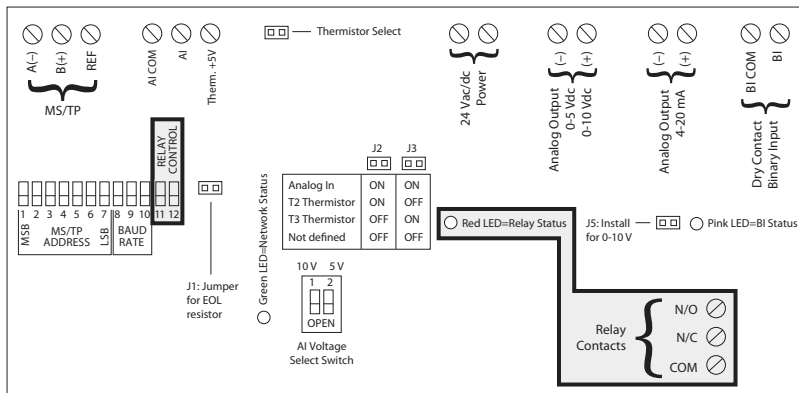

- Relay Override is selected via DIP Sw 11 & 12:

DIP Switches *		Relay State **
11	12	
1	0	Auto
X	1	Override on
0	0	Override off

\* 0 = Open ; 1 = Closed  
 \*\* Device must be powered for override

- Red LED is on when Relay is on.
- Connect to terminals N/O, N/C, COM

## One Binary Input (Dry Contact, Class 2)

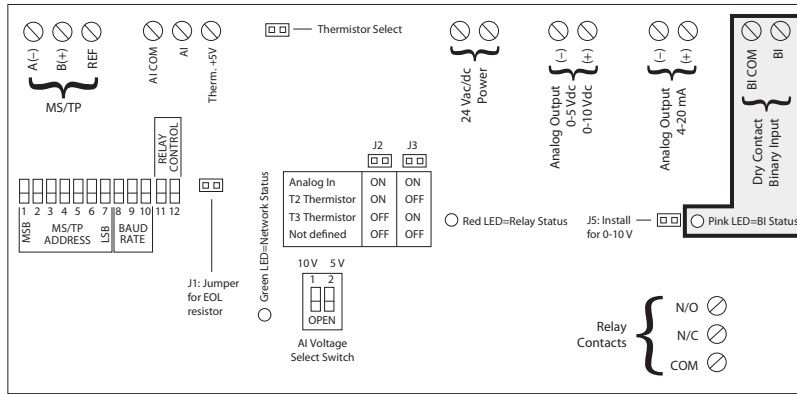

- Connect to terminal pair BI COM & BI
- Contact rating ~ 24 Vdc @ 20 mA
- Pink LED is on when Binary Input is closed

## One Analog Output (Voltage or Current)

- For best analog output accuracy, apply power input within the range of 22 Vac/dc to 28 Vac/dc.

	Analog Output Accuracy as a Function of Output Span (using Standard Conditions *)		
	Span 20% - 100%	Span 10% - 100%	Span 0% - 100%
Analog Output Voltage (0-5 Vdc; 0-10 Vdc)	+/- 2% error	+/- 5% error	+/- 11% error
Analog Output Current (4-20 mA)	+/- 2% error	+/- 3% error	+/- 12% error

### \* Standard Conditions:

Power Supply Input: 22 Vac/dc to 28 Vac/dc

Loop Resistance (Analog Output 4-20 mA Loop): 530 Ohms max.

Load Resistance [Analog Output Voltage (0-5 Vdc, 0-10 Vdc)]: 10 K Ohms min.

Ambient Temperature: -30 to 140° F

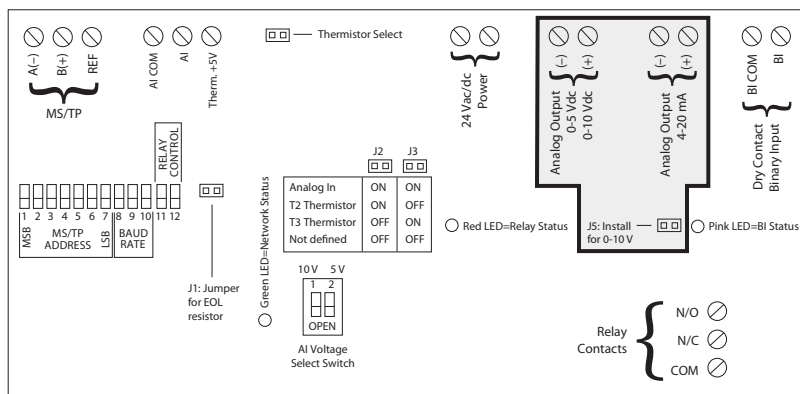

- Analog Voltage Output (0-5 Vdc / 0-10 Vdc)
  - Install 0-10V jumper (J5) for 0-10 Vdc
  - Uninstall 0-10V jumper (J5) for 0-5 Vdc
  - Connect to terminal pair AO (-) & 0-10V (+)
- Analog Current Output (4-20 mA, Self-Powered)
  - Uninstall 0-10V jumper (J5)
  - Connect to terminal pair AO (-) & 4-20mA (+)

## One Analog Input (T2/T3 Thermistor or 0-5 Vdc or 0-10 Vdc)

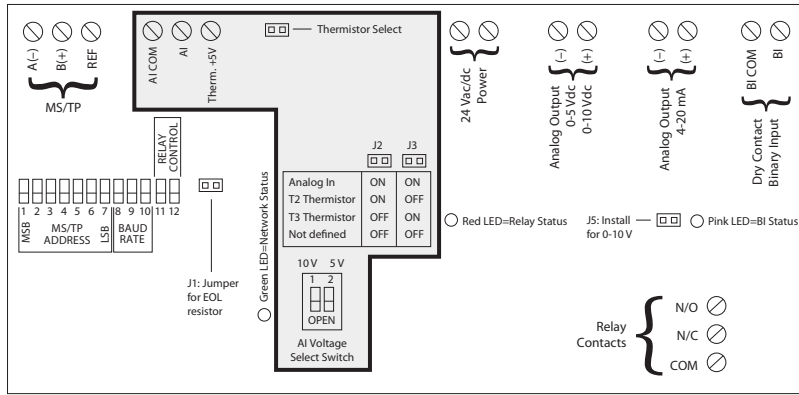

- T2/T3 Thermistor
  - Install THERM SELECT Jumper
  - Install either J2 or J3 per Type Select Table
  - Open Sw 1
  - Close Sw 2
  - Connect to Terminals AI & THERM +5V
  
- Thermistor Specifications
  - Thermistor Type 2 (T2) Precon 10 K @ 77°F (25°C) PN ST-R24, Model 24, (or equivalent.)
  - Thermistor Type 3 (T3) Precon 10 K @ 77°F (25°C) Model 3, (or equivalent.)
  - Thermistor not included.
  
- For both T2 and T3:
  - MIN\_PRES\_VAL must be set to -36 Celcius or -32.8 Fahrenheit (real value)
  - MAX\_PRES\_VAL must be set to 66.3 Celcius or 151.34 Fahrenheit (real value).
  
- Temperature Range/Resolution:
  - -35 to 10°C range in 1° steps / -31 to 50°F range in 1.8° steps
  - 10 to 32°C range in 0.1° steps / 50 to 90°F range in 0.18° steps
  - 32 to 100°C range in 1° steps / 90 to 212°F range in 1.8° steps
  
- Input (0-5 Vdc)
  - Uninstall THERM SELECT Jumper
  - Install both J2 and J3 per Type Select Table
  - Open Sw 1
  - Close Sw 2
  - Connect to Terminals AI & AI COM
  
- Input (0-10 Vdc)
  - Uninstall THERM SELECT Jumper
  - Install both J2 and J3 per Type Select Table
  - Close Sw 1
  - Open Sw 2
  - Connect to Terminals AI & AI COM
  
- Raw analog default settings are 0 and 1023 (real), respectively. Units default to 95 (no units).

## 24 Vac/dc Power Input

- Use a separate 24 Vac transformer, or an isolated 24 Vdc power supply to power-up this product.
- Connect to terminal pair COM & 24V

## BACnet® MS/TP Network

- Optional End of Line Resistor (EOL) Included.
- Basic Data
  - **Network Media:** Twisted Pair 22-24AWG, shielded recommended
  - **Terminations:** Functional Devices product installed at both ends of the MS/TP network – Use 120 Ω end of line resistors. All other cases – Follow instructions from the device installed at the end of the MS/TP network.
  - **Polarity:** Network is polarity sensitive
  - **Baud Rate:** 9600, 19200, 38400, 57600, 76800, 115200 (DIP Switch Selectable)

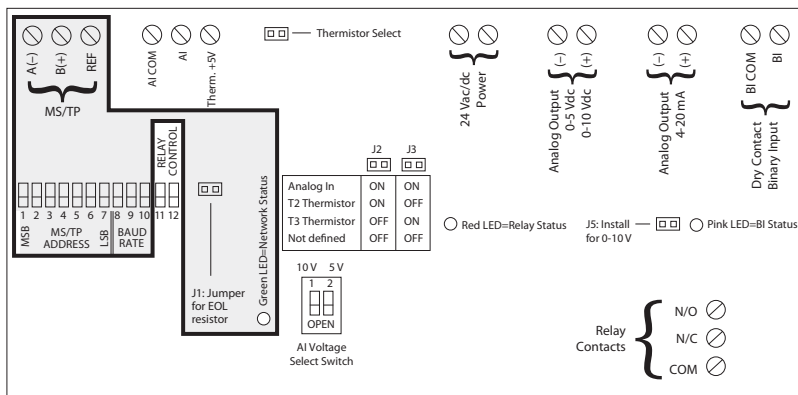

- **MS/TP Addressing, Baud Rate, and ID**
  - MS/TP Address & Baud Rate must be set prior to power up via DIP switches.
  - Device ID will default to 277XXX where XXX is the MS/TP Address.
    - Examples:
      - MS/TP Address - 004 Device ID - 277004
      - MS/TP Address - 121 Device ID - 277121
  - Device ID can be changed via network command. Once changed, it will no longer default to 277XXX. (Each MS/TP Address & Device ID must be unique.)
  - This model utilizes: BO 1 (Relay output), BI 1 (Dry contact binary input), AI 1 (Analog input), AO 1 (Analog output)
  - Device Instance is changed via Object-Identifier Property of the Device Object

DIP Switches*			Baud Rate
8	9	10	
0	0	0	9600
0	0	1	19200
0	1	0	38400
0	1	1	57600
1	0	0	76800
1	0	1	115200

\* 0 = Open ; 1 = Closed  
All other combinations = 9600 Baud

- Address selected via DIP Sw 1 – 7 , see Bulletin B1082