

INSTRUCTIONS



Carrier

A United Technologies Company



99TA526399A (for RCD use only)

Instruction Sheet Number: **99TA526399A**

Description: SUCTION LINE ACCUMULATOR INSTALLATION

Author: Bob Loomis

Date: June 4, 2010

Part Number: 38AK500410, KH73LZ001

SAFETY CONSIDERATIONS

Installing, starting up, and servicing air-conditioning equipment can be hazardous due to system pressures, electrical components and equipment location.

Only trained, qualified installers and service technicians should install, start up, and service this equipment.

When working on air-conditioning equipment, observe precautions in the literature, on tags, stickers, and labels attached to the equipment.

Follow all safety codes. Wear safety glasses and work gloves. Use care in handling equipment.

⚠ WARNING

Before beginning any modification, be sure the main electrical disconnect is in the OFF position. TAG THE DISCONNECT SWITCH WITH A SUITABLE WARNING LABEL. Electrical shock can cause personal injury or death.

GENERAL

This Instruction sheet provides suggested installation of suction line accumulators on 38AKS/38AH condensing units when required.

INSTALLATION

Examine the package content for the correct accumulator part number. If the accumulator is damaged, file a claim with the shipping company and notify a Carrier representative.

See Table 1 for proper accumulator part numbers and unit requirements, note that fusible plugs, and in some cases an accumulator bracket must be ordered separately.

Table 1

Suction Line Accumulators For 38 Series Condensing Units			
Unit Model Number	Accumulator Part Number	Fusible Plug	Accumulator Bracket
38AKS028 – 38AKS044	38AK500410 (1 req.)	EK02JA170 (1 req.)	NA
38AH044 – 38AH084 Dual Circuit	38AK500410 (2 req.)	EK02JA170 (2 req.)	38AK500398 (2 req.)
38AH024 – 38AH034	KH73LZ001 (2 req.)	EK02JA170 (2 req.)	NA

Note: All 38AH044-084 single circuit units, 38AH094-134 units, and 38AH044-084 VAV FIOP units have factory installed accumulators : No field conversion accumulator is required.

Applications

Field supplied suction line accumulators must be installed on 38AH/AKS units identified in table above anytime the suction line linear length exceeds 75ft. Failure to install an accumulator could void warranty.

NOTE: Accumulators cannot be installed inside cabinets of 38AH024-034 units due to lack of interior space. Accumulators must be installed outside of cabinet on field- supplied mountings.

Install accumulator inside compressor compartment in suction line as follows. If installing it outside compressor compartment install as close to compressor as possible.

1. Close suction service valve on compressor.
2. Cut and remove suction pipe at location where accumulator will be installed.
3. Unit should have a slight nitrogen purge while installing accumulator to prevent contamination.
4. Install accumulator, keeping top of accumulator below top of factory installed vertical riser, using field-supplied street elbows, 90-degree elbows, couplings, and straight tubing.
5. Check for leaks. Evacuate and recharge system per Carrier GTAC II, Module 5, Charging, Recovery, Recycling, and Reclamation, and chart on unit.

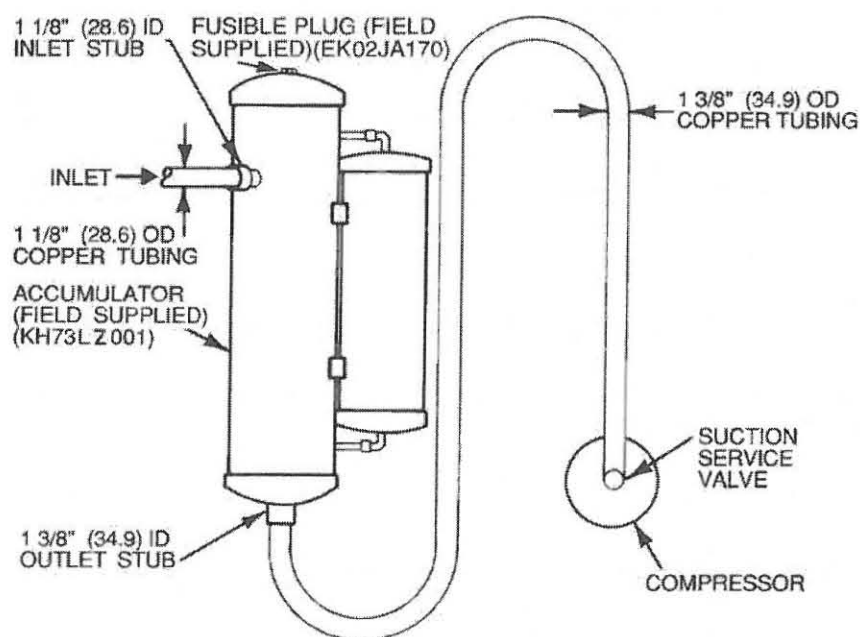

NOTE: Dimensions in () are in millimeters.

Installation of Accumulator KH73LZ001 Shown

Typical installation of a 38AH024 – 38AH034 Dual Circuit

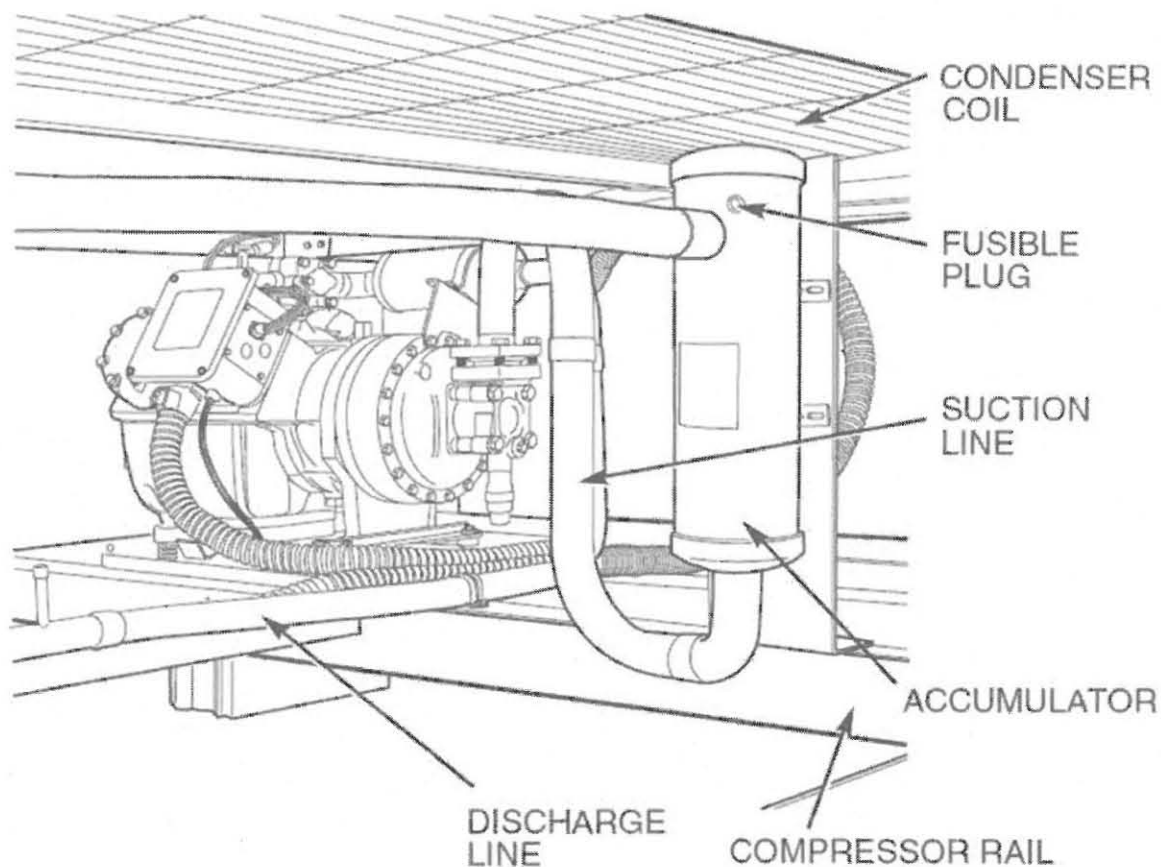

Installation of Accumulator 38AK500410 Shown

Typical installation of a 38AH044 – 38AH084 Dual Circuit

