

WEISS INSTRUMENTS
20DT DIGITAL THERMOMETER
INSTALLATION AND OPERATING
INSTRUCTIONS

⚠ PLEASE READ THIS MANUAL FULLY!

- This manual is part of the product and should be kept near the device for easy and quick reference.

1. GENERAL DESCRIPTION

The 20DT is an electronic digital thermometer which displays the current temperature and also logs the maximum and minimum temperatures experienced. With the use of an Optional momentary switch the min. / max. temperatures can be displayed at the touch of a button and reset if required. (Switch sold separately) A 9 Volt battery can supply backup power for temperature readings when there is a blackout. (Battery bracket and harness sold separately)

2. INSTALLATION

The instrument is equipped with fast-on type spade terminals with probe connections separated from the power supply connections. To install the instrument proceed as follow:

1. Make a 2.04 inch round hole in the panel.
2. a) If the model is flanged with three screw holes space the holes on the panel as seen in (FIG.1). Then use # 6 sheet metal screws to hold the thermometer in the panel.
 b) If the model is U-Clamp mounted slide the U-Clamp over the nylon stud and use the thumb nut to tighten the thermometer to the panel (FIG.3).
3. Place the probe where it has to measure the temperature. Be sure to leave slack so as to have some strain relief. Probe bulb should have the end up vertically or on at least a slight angle to try to prevent water intrusion into the sensor. Were a sharp bend is required try to loop the probe wire in a 1 1/2 "circle.
4. Connect the probe terminals to the two small (.110 inch) fast-ons as indicated.
5. Connect the power supply cables to the large (.250 inch) fast-ons. (N or NEUTRAL) to the fast-on on the top and (L OR HOT) to the fast-on on the bottom. SEE fig.2

3. DRAWINGS

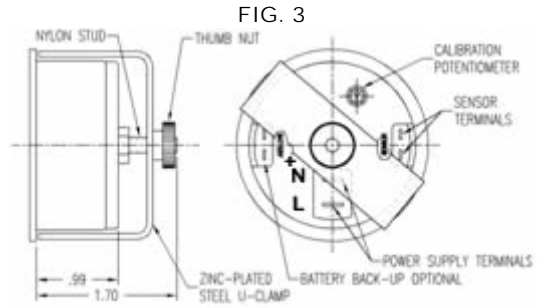
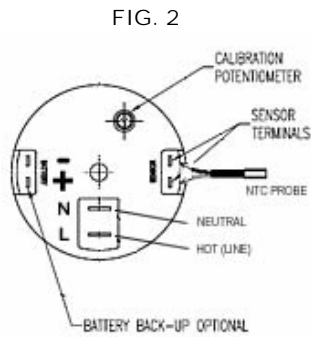
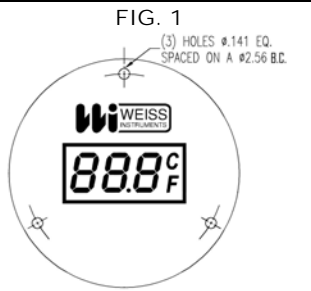

4. ALARM DISPLAY

MESSAGE	CAUSE
PO	OPEN PROBE OR SWITCH CLOSED
LO	LO TEMP RECORDED
HI	HI TEMP RECORDED
rE	RECORDED TEMP IS RESET
P1	NO PROBE CONNECTED

5. OPTIONAL SWITCH WIRING FOR MIN / MAX

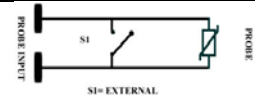



To use the optional momentary switch to view low and high temperatures you have to wire the switch in parallel with the probe. When the switch is open the thermometer will display the current temperature. When the switch is held the display will show "PO" Then "LO" followed by the low temperature recorded. Immediately after the display will read "HI" with the recorded high temperature to follow.
 To reset the temperatures stored hold the switch closed through the above procedure until "rE" is displayed.

SAFETY PRECAUTIONS

- Always ensure that the probe is connected to the instrument before the power supply is connected and turned ON.
- Check the supply voltage is correct before connecting the instrument. Always ensure that the power is connected as directed in fig.2.
- The instrument is designed for panel mounting and electrical connections must be positioned inside a properly protected board/panel.
- The probe is double insulated for safety on models with 110V/230V power supply.
- Do not expose to water or moisture: use the instrument only within the operating limits avoiding sudden temperature changes with high atmospheric humidity to prevent the formation of condensation.
- Warning: disconnect all electrical connections before any kind of maintenance.
- The instrument shall never be opened.
- In case of failure or faulty operation send the instrument back to the distributor or Weiss Instruments (see address) with a detailed description of the fault. Please see the website for warranty information.
- Be sure that the wires for probes and for the power supply are separated and far enough from each other, without crossing and coiling.

20DT_UNIVERSAL_mm_10_19_09_final





WEISS INSTRUMENTS, INC.
 905 WAVERLY AVE.
 HOLTSTVILLE, NY 11742
 PHONE: 631-207-1200
 FAX: 631-207-0900
www.weissinstruments.com
sales@weissinstruments.com

WEISS INSTRUMENTS

24DT DIGITAL THERMOMETER

INSTALLATION AND OPERATING INSTRUCTIONS

⚠ PLEASE READ THIS MANUAL FULLY!

• This manual is part of the product and should be kept near the device for easy and quick reference.

1. GENERAL DESCRIPTION

The 24DT is an electronic digital thermometer which displays the current temperature and also logs the maximum and minimum temperatures experienced. With the use of an Optional momentary switch the min. / max. Temperatures can be displayed at the touch of a button and reset if required. (Switch sold separately) A 9 Volt battery can supply backup power for temperature readings when there is a blackout. (Battery bracket and harness sold separately)

2. INSTALLATION

The instrument is equipped with fast-on type spade terminals with probe connections separated from the power supply connections. To install the instrument proceed as follow:

1. Attach .250 inch Fast-on connectors to the wires for the interior light.
2. Wire the switch according to the drawing Fig. 1.
3. Place the probe where it has to measure the temperature. Be sure to leave slack so as to have some strain relief. Probe bulb should have the end up vertically or on at least a slight angle to try to prevent water intrusion into the sensor. Were a sharp bend is required try to loop the probe wire in a 1 1/2 "circle.
4. Connect the probe terminals to the two small (.110 inch) fast-on connectors as indicated.
5. **Connect the power supply cables to the large (.250 inch) fast-ons. (N or NEUTRAL) to the fast-on on the LEFT and (L OR HOT) to the fast-on on the RIGHT. SEE fig.2**
6. There should be .63mA fuse on the Line.
7. If using the optional 9V battery back up install it on the connectors at the top left of the thermometer.

3. DRAWINGS

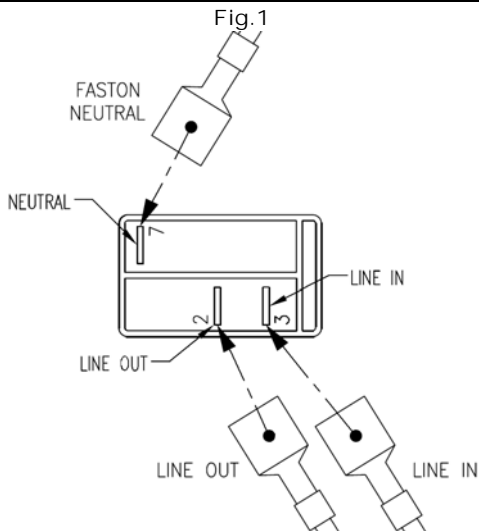
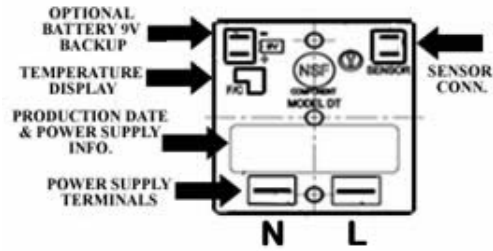

Fig. 2



NOTE: POWER SUPPLY AS STATED ON UNIT LABEL!

4. ALARM DISPLAY

MESSAGE	CAUSE
PO	OPEN PROBE OR SWITCH CLOSED
P1	NO PROBE CONNECTED

SAFETY PRECAUTIONS

- Always ensure that the probe is connected to the instrument before the power supply is connected and turned ON.
- **Check the supply voltage is correct before connecting the instrument. (12V, 120V, 230V) (N or NEUTRAL) to the fast-on at the LEFT (L OR HOT) to the fast-on at the RIGHT. SEE fig.2**
- **The probe is double insulated for safety on models with 110V and 230V power supply.**
- The instrument is designed for panel mounting and electrical connections must be positioned inside a properly protected board/panel.
- Do not expose to water or moisture: use the instrument only within the operating limits avoiding sudden temperature changes with high atmospheric humidity to prevent the formation of condensation.
- Warning: disconnect all electrical connections before any kind of maintenance.
- The instrument shall never be opened.
- In case of failure or faulty operation send the instrument back to the distributor or Weiss Instruments (see address) with a detailed description of the fault.
- Be sure that the wires for probes and for the power supply are separated and far enough from each other, without crossing and coiling.



WEISS INSTRUMENTS, INC.
905 WAVERLY AVE.
HOLTSVILLE, NY 11742
PHONE: 631-207-1200
FAX: 631-207-0900



MODEL DT



www.weissinstruments.com
sales@weissinstruments.com

See the website for warranty information.

WEISS INSTRUMENTS
24DT
DIGITAL THERMOMETER
3 WAY SWITCH
INSTALLATION AND OPERATING INSTRUCTIONS

⚠ PLEASE READ THIS MANUAL FULLY!

- This manual is part of the product and should be kept near the device for easy and quick reference.

1. GENERAL DESCRIPTION

The 24DT is an electronic digital thermometer which displays the current temperature and also logs the maximum and minimum temperatures experienced. With the use of an Optional momentary switch the min. / max. Temperatures can be displayed at the touch of a button and reset if required. (Switch sold separately) A 9 Volt battery can supply backup power for temperature readings when there is a blackout. (Battery bracket and harness sold separately)

2. INSTALLATION

The instrument is equipped with fast-on type spade terminals with probe connections separated from the power supply connections. To install the instrument proceed as follow:

- Attach .250 inch Fast-on connectors to the wires for the interior light and the wires connecting the switches.
- Wire the 3 way switch according to the drawing Fig. 1.
- Place the probe where it has to measure the temperature. Be sure to leave slack so as to have some strain relief. Probe bulb should have the end up vertically or on at least a slight angle to try to prevent water intrusion into the sensor. Were a sharp bend is required try to loop the probe wire in a 1 1/2 "circle.
- Connect the probe terminals to the two small (.110 inch) fast-on connectors as indicated.
- Connect the power supply cables to the large (.250 inch) fast-ons. (N or NEUTRAL) to the fast-on on the LEFT and (L OR HOT) to the fast-on on the RIGHT. SEE fig.2**
- There should be .63mA fuse on the Line.
- If using the optional 9V battery back up install it on the connectors at the top left of the thermometer.

3. DRAWINGS

Fig.1

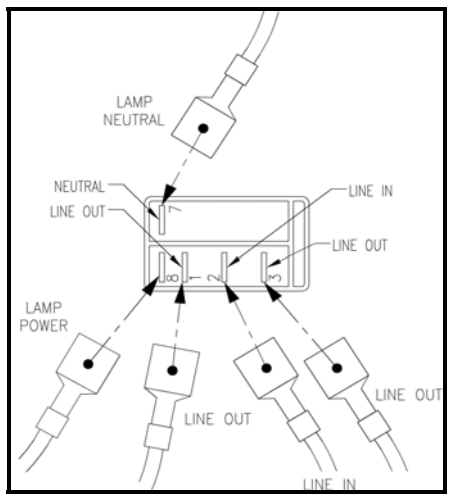
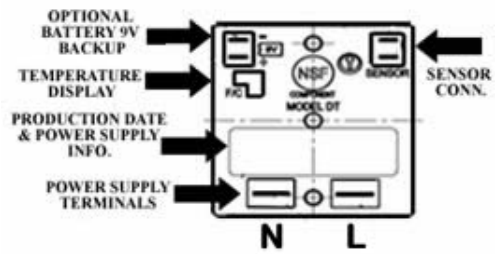

Fig. 2



NOTE: POWER SUPPLY AS STATED ON UNIT LABEL!

4. ALARM DISPLAY	
MESSAGE	CAUSE
PO	OPEN PROBE OR SWITCH CLOSED
P1	NO PROBE CONNECTED

SAFETY PRECAUTIONS

- Always ensure that the probe is connected to the instrument before the power supply is connected and turned ON.
- Check the supply voltage is correct before connecting the instrument. (12V, 120V, 230V) (N or NEUTRAL) to the fast-on at the LEFT and (L OR HOT) to the fast-on at the RIGHT. SEE fig.2
- The probe is double insulated for safety on models with 110V and 230V power supply.
- Check the supply voltage is correct before connecting the instrument. (12V, 120V, 230V)
- The probe is double insulated for safety on models with 110V and 230V power supply.
- The instrument is designed for panel mounting and electrical connections must be positioned inside a properly protected board/panel.
- Do not expose to water or moisture: use the instrument only within the operating limits avoiding sudden temperature changes with high atmospheric humidity to prevent the formation of condensation.
- Warning: disconnect all electrical connections before any kind of maintenance.
- The instrument shall never be opened.
- In case of failure or faulty operation send the instrument back to the distributor or Weiss Instruments (see address) with a detailed description of the fault.
- Be sure that the wires for probes and for the power supply are separated and far enough from each other, without crossing and coiling.



model DT



WEISS INSTRUMENTS, INC.
 905 WAVERLY AVE.
 HOLTSVILLE, NY 11742
 PHONE: 631-207-1200
 FAX: 631-207-0900

www.weissinstruments.com
sales@weissinstruments.com

Please see website for warranty information.

Installation and Operating Instructions

XT11S

ELECTRONIC DIGITAL THERMOMETER
WITH MAX / MIN TEMPERATURE LOG.

GENERAL WARNINGS

⚠ Please read before using this manual

- This manual is part of the product and shall be kept near the device for easy and quick reference.
- Check the application limits before proceeding.

Safety Precautions

- Always ensure that the probe is connected to the instrument before the power supply is connected and turned ON.
- Check the supply voltage is correct before connecting the instrument.
- The probe is under NO extra low safety voltage. (Models with 230Vac Power supply)
- The instrument is designed for panel mounting and electrical connections must be positioned inside a properly protected board/panel.
- Do not expose to water or moisture: use the instrument only within the operating limits avoiding sudden temperature changes with high atmospheric humidity to prevent condense formation.
- Warning: disconnect all electrical connections before any kind of maintenance.
- The instrument shall never be opened.
- In case of failure or faulty operation send the instrument back to the retailer or to "Dixell s.r.l." (see address) with a detailed description of the fault.
- Assure that the wires for probes and for power supply are separated and far enough from each other, without crossings and spirals.

General description

The XT11S is a new electronic digital thermometer which displays the current temperature and also logs the maximum and minimum temperatures experienced. These max. / min. temperatures can be displayed at the touch of a button and reset if required.

Installation (Fig.1)

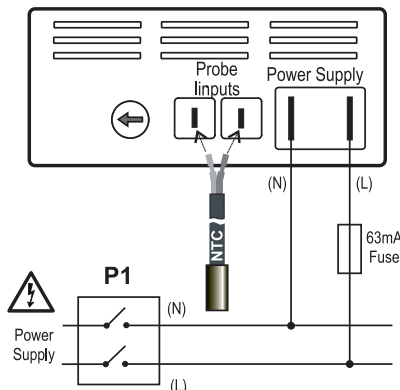

Fig. 1

The instrument is equipped with fast-on type spade terminals

with probe connections separated from the power supply connections. To install the instrument proceed as follow:

- Make a 59x25,5 mm (1.01x2.32 inch) hole in a panel with max. thickness 2.7mm.
- Take the instrument from the box and place it in the hole until the side flaps click, which means they are locked.
- ⚠ Disconnect the power supply from the board by means of the panel switch (P1 in Fig.1)**
- Place the probe where it has to measure the temperature.
- Connect the probe terminals to the 2.8mm. fast-ons as indicated.
- Connect the power supply cables to the 6.3mm. fast-ons.
- If possible, the manufacturer suggests connecting the phase (L) to the fast-on on the right and neutral (N) to the fast-on on the left as indicated.
- At this stage the board can be connected to the power supply once more.

Disconnection and probe substitution (Fig.1)

- ⚠ Disconnect the power supply on the board where the instrument is positioned, by means of the panel switch (P1 in Fig.1)**
- Remove the power supply fast-ons.
- Disconnect the instrument and the probe.

External push-button connection (Fig.2)

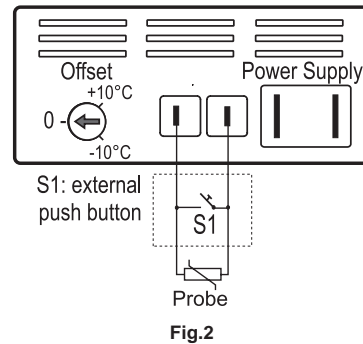

Fig.2

In order to display the maximum and minimum values on the instrument, use the S1 Class II approved type push button, normally open. (NOT SUPPLIED).

- Before carrying out the connections, disconnect the power supply on the board where the instrument is positioned.
- Connect the push button in parallel with the probe as shown in Fig.2.

Display of min. and max. temperatures logged

Once the button for min. & max. temperatures has been connected, proceed as follows:

Maximum temperature display:

- Press and hold the push button (S1) until the display reads "HI".
- Release S1 and the highest temperature recorded since the last reset will be displayed for 3 seconds.

Minimum temperature display:

- Press and hold the push button (S1) until the display reads "LO".
- Release S1 and the lowest temperature recorded since the

Installation and Operating Instructions

XT11S

ELECTRONIC DIGITAL THERMOMETER
WITH MAX / MIN TEMPERATURE LOG.

GENERAL WARNINGS

⚠ Please read before using this manual

- This manual is part of the product and shall be kept near the device for easy and quick reference.
- Check the application limits before proceeding.

Safety Precautions

- Always ensure that the probe is connected to the instrument before the power supply is connected and turned ON.
- Check the supply voltage is correct before connecting the instrument.
- The probe is under NO extra low safety voltage. (Models with 230Vac Power supply)
- The instrument is designed for panel mounting and electrical connections must be positioned inside a properly protected board/panel.
- Do not expose to water or moisture: use the instrument only within the operating limits avoiding sudden temperature changes with high atmospheric humidity to prevent condense formation.
- Warning: disconnect all electrical connections before any kind of maintenance.
- The instrument shall never be opened.
- In case of failure or faulty operation send the instrument back to the retailer or to "Dixell s.r.l." (see address) with a detailed description of the fault.
- Assure that the wires for probes and for power supply are separated and far enough from each other, without crossings and spirals.

General description

The XT11S is a new electronic digital thermometer which displays the current temperature and also logs the maximum and minimum temperatures experienced. These max. / min. temperatures can be displayed at the touch of a button and reset if required.

Installation (Fig.1)

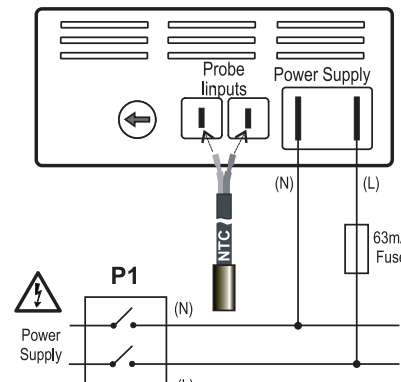

Fig. 1

The instrument is equipped with fast-on type spade terminals

with probe connections separated from the power supply connections. To install the instrument proceed as follow:

- Make a 59x25,5 mm (1.01x2.32 inch) hole in a panel with max. thickness 2.7mm.
- Take the instrument from the box and place it in the hole until the side flaps click, which means they are locked.
- ⚠ Disconnect the power supply from the board by means of the panel switch (P1 in Fig.1)**
- Place the probe where it has to measure the temperature.
- Connect the probe terminals to the 2.8mm. fast-ons as indicated.
- Connect the power supply cables to the 6.3mm. fast-ons.
- If possible, the manufacturer suggests connecting the phase (L) to the fast-on on the right and neutral (N) to the fast-on on the left as indicated.
- At this stage the board can be connected to the power supply once more.

Disconnection and probe substitution (Fig.1)

- ⚠ Disconnect the power supply on the board where the instrument is positioned, by means of the panel switch (P1 in Fig.1)**
- Remove the power supply fast-ons.
- Disconnect the instrument and the probe.

External push-button connection (Fig.2)

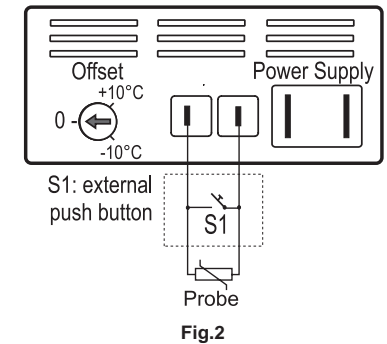

Fig.2

In order to display the maximum and minimum values on the instrument, use the S1 Class II approved type push button, normally open. (NOT SUPPLIED).

- Before carrying out the connections, disconnect the power supply on the board where the instrument is positioned.
- Connect the push button in parallel with the probe as shown in Fig.2.

Display of min. and max. temperatures logged

Once the button for min. & max. temperatures has been connected, proceed as follows:

Maximum temperature display:

- Press and hold the push button (S1) until the display reads "HI".
- Release S1 and the highest temperature recorded since the last reset will be displayed for 3 seconds.

Minimum temperature display:

- Press and hold the push button (S1) until the display reads "LO".
- Release S1 and the lowest temperature recorded since the

last reset will be displayed for 3 seconds.

Probe offset value display:

1. Press and hold the push button (S1) until the display reads "PO".
2. Release S1 and the probe offset value will be displayed for 3 seconds.

Maximum /minimum temperature reset:

1. Press and hold the push button (S1) until the display reads "rE".
2. Release S1 and the display will flash "rE" for 5 seconds.
3. While the display is flashing press the push button and the max&min temperature will be erased..

Power on and power failure warning:

When the power supply is turned on and after any power failure, when the max. and min. set values are visualised, the display flashes. This is to warn the user that there has been an interruption to the power supply.

To restore normal operation, follow the same procedure that is used for re-setting the maximum/minimum memory. (see **Maximum /minimum temperature reset**).

Maintenance and cleaning

Instruments do not require particular maintenance. To clean frontal, just use a soft moist cloth and avoid using any strong detergent or solvent.

Technical Data

Case: 64x31mm, depth: 31mm; self extinguishing polycarbonate (ULV2)

Mounting: only for panel mounting; 25,5x59mm panel cut out (1.01x2.32inc.)

Frontal protection: IP65

Electrical connections: fast-on type spade terminals with probe connections (2.8mm) separated from power supply connections (6.3mm).

Power supply: 230Vac $\pm 10\%$ 50/60Hz or 120Vac $\pm 10\%$ 50/60 or 12Vac/dc $\pm 10\%$ or 24Vac/dc $\pm 10\%$;

Max. Absorbed current: 42mA (nominal 35mA)

Probe: NTC with double isolation

Display and measurement units:

2 digits model: $-50\div 99\text{ }^{\circ}\text{C}$ ($-58\div 99\text{ }^{\circ}\text{F}$)

3 digits model: $-50.0\div 99.9\text{ }^{\circ}\text{C} \Rightarrow 100\text{ to }110\text{ }^{\circ}\text{C}$; $58\div 230\text{ }^{\circ}\text{F}$

NTC standard probe: $-30\div 80\text{ }^{\circ}\text{C}$ ($-22\div 176\text{ }^{\circ}\text{F}$)

Display update delay times (optional) when the temperature increases: fixed at 1 or 3 minutes depending on model specified at time of order.

Operating temperature: $0\div 60\text{ }^{\circ}\text{C}/32\div 140\text{ }^{\circ}\text{F}$

Storage temperature: $-30\div 75\text{ }^{\circ}\text{C}/-22\div 167\text{ }^{\circ}\text{F}$.

Relative humidity: 20÷85% (no condensing)

Maximum working height: 2000m a. s. l.

Installation category III; transitory overvoltage 4000V; pollution degree 2 according to IEC 664.

Offset: $\pm 10\text{ }^{\circ}\text{C}$ ($\pm 17\text{ }^{\circ}\text{F}$)

Accuracy: from -30 to $-10\text{ }^{\circ}\text{C}$ ($-22\div 14\text{ }^{\circ}\text{F}$): $1\text{ }^{\circ}\text{C}$ ($2\text{ }^{\circ}\text{F}$) ± 1 digit

From -10 to $110\text{ }^{\circ}\text{C}$ ($14\div 230\text{ }^{\circ}\text{F}$): $0,5\text{ }^{\circ}\text{C}$ ($1\text{ }^{\circ}\text{F}$) ± 1 digit

Installation and Operating Instructions

GB

XT11S

ELECTRONIC DIGITAL THERMOMETER

WITH MAXIMUM / MINIMUM TEMPERATURE LOG

last reset will be displayed for 3 seconds.

Probe offset value display:

1. Press and hold the push button (S1) until the display reads "PO".
2. Release S1 and the probe offset value will be displayed for 3 seconds.

Maximum /minimum temperature reset:

1. Press and hold the push button (S1) until the display reads "rE".
2. Release S1 and the display will flash "rE" for 5 seconds.
3. While the display is flashing press the push button and the max&min temperature will be erased..

Power on and power failure warning:

When the power supply is turned on and after any power failure, when the max. and min. set values are visualised, the display flashes. This is to warn the user that there has been an interruption to the power supply.

To restore normal operation, follow the same procedure that is used for re-setting the maximum/minimum memory. (see **Maximum /minimum temperature reset**).

Maintenance and cleaning

Instruments do not require particular maintenance. To clean frontal, just use a soft moist cloth and avoid using any strong detergent or solvent.

Technical Data

Case: 64x31mm, depth: 31mm; self extinguishing polycarbonate (ULV2)

Mounting: only for panel mounting; 25,5x59mm panel cut out (1.01x2.32inc.)

Frontal protection: IP65

Electrical connections: fast-on type spade terminals with probe connections (2.8mm) separated from power supply connections (6.3mm).

Power supply: 230Vac $\pm 10\%$ 50/60Hz or 120Vac $\pm 10\%$ 50/60 or 12Vac/dc $\pm 10\%$ or 24Vac/dc $\pm 10\%$;

Max. Absorbed current: 42mA (nominal 35mA)

Probe: NTC with double isolation

Display and measurement units:

2 digits model: $-50\div 99\text{ }^{\circ}\text{C}$ ($-58\div 99\text{ }^{\circ}\text{F}$)

3 digits model: $-50.0\div 99.9\text{ }^{\circ}\text{C} \Rightarrow 100\text{ to }110\text{ }^{\circ}\text{C}$; $58\div 230\text{ }^{\circ}\text{F}$

NTC standard probe: $-30\div 80\text{ }^{\circ}\text{C}$ ($-22\div 176\text{ }^{\circ}\text{F}$)

Display update delay times (optional) when the temperature increases: fixed at 1 or 3 minutes depending on model specified at time of order.

Operating temperature: $0\div 60\text{ }^{\circ}\text{C}/32\div 140\text{ }^{\circ}\text{F}$

Storage temperature: $-30\div 75\text{ }^{\circ}\text{C}/-22\div 167\text{ }^{\circ}\text{F}$.

Relative humidity: 20÷85% (no condensing)

Maximum working height: 2000m a. s. l.

Installation category III; transitory overvoltage 4000V; pollution degree 2 according to IEC 664.

Offset: $\pm 10\text{ }^{\circ}\text{C}$ ($\pm 17\text{ }^{\circ}\text{F}$)

Accuracy: from -30 to $-10\text{ }^{\circ}\text{C}$ ($-22\div 14\text{ }^{\circ}\text{F}$): $1\text{ }^{\circ}\text{C}$ ($2\text{ }^{\circ}\text{F}$) ± 1 digit

From -10 to $110\text{ }^{\circ}\text{C}$ ($14\div 230\text{ }^{\circ}\text{F}$): $0,5\text{ }^{\circ}\text{C}$ ($1\text{ }^{\circ}\text{F}$) ± 1 digit

Installation and Operating Instructions

GB

XT11S

ELECTRONIC DIGITAL THERMOMETER

WITH MAXIMUM / MINIMUM TEMPERATURE LOG

dixell®

Dixell srl

Via dell'Industria, 27
32010 Pieve d'Alpago (BL)

tel +39-0437-98 33 - fax +39-0437-989 313

WEB: www.dixell.com - E-mail: dixell@dixell.com

cod. 1592002500 - r.1.0 - 20/11/00

XT11S
at 230Vac



106681



XT11S
at 230Vac



106681



dixell®

Dixell srl

Via dell'Industria, 27
32010 Pieve d'Alpago (BL)

tel +39-0437-98 33 - fax +39-0437-989 313

WEB: www.dixell.com - E-mail: dixell@dixell.com

cod. 1592002500 - r.1.0 - 20/11/00