

EFFECTIVE:
16-SEP-14

DIMENSION PRINT

UNIMOUNT WITH OVERSIZED OUTLET BOX

PRINT:
07-2879-01

SUPERSEDES:
31-OCT-12

FRAME: 254-256T
BASIC TYPE: UT

SHEET:
1 OF 1

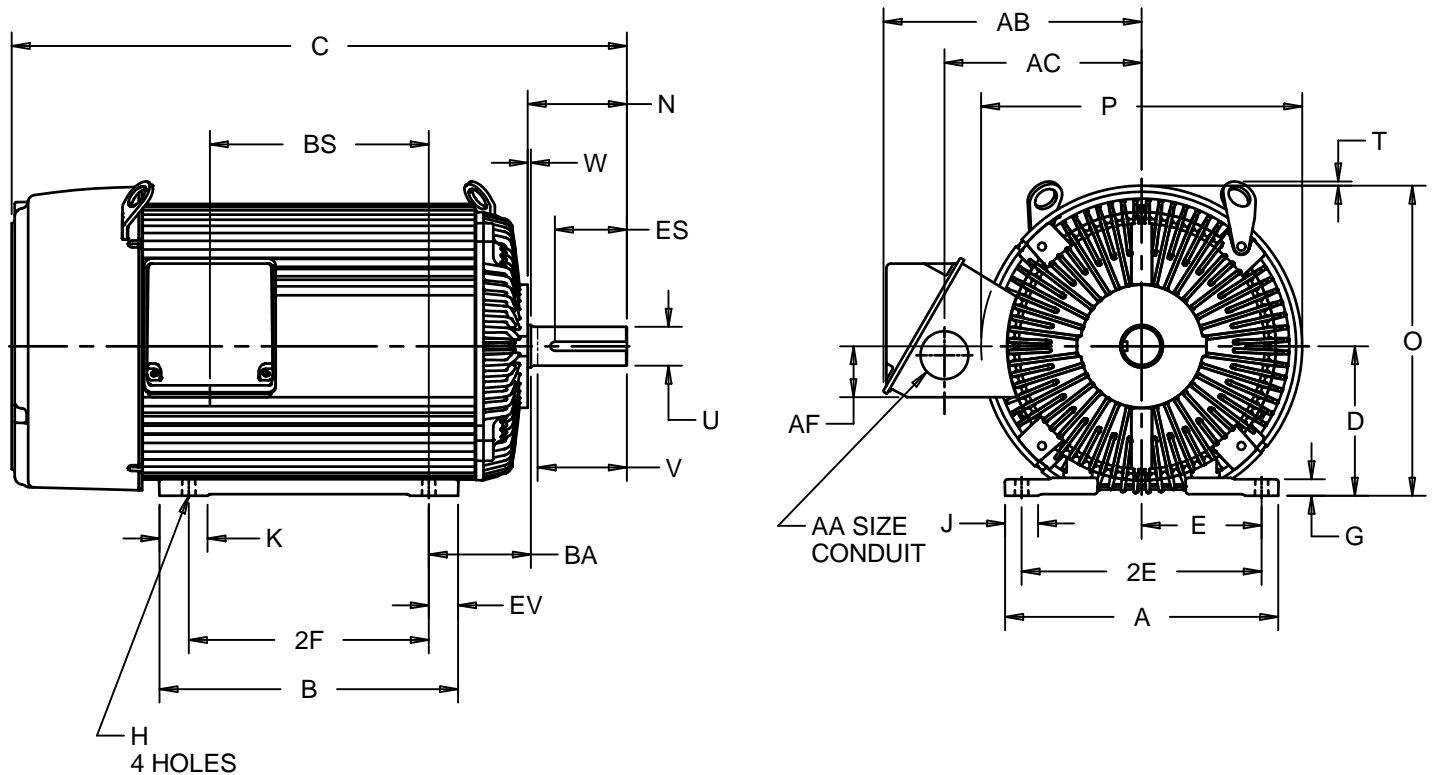

ALL DIMENSIONS ARE IN INCHES AND MILLIMETERS

UNITS	A	D -.06	E	2E ±.03	G	H +.05	J	K	N	O	P ²	T	U -.001
IN	11.38	6.25	5.00	10.00	.69	.53	1.38	2.00	4.13	12.94	13.38	.16	1.625
MM	289	159	127	254	17	13	35	51	105	329	340	4	41.28

UNITS	V MIN	W	AA	AB	AC	AF	BA	ES MIN	EV	SQ KEY
IN	3.72	.13	1.50	10.75	8.22	2.13	4.25	2.28	1.22	.375
MM	94	3		273	209	54	108	58	31	9.53

FRAME	UNITS	B	C	2F ±.03	BS
254T	IN	10.69	23.88	8.25	7.38
	MM	271	607	210	187
256T	IN	12.44	25.63	10.00	9.13
	MM	316	651	254	232

1: ALL ROUGH CASTING DIMENSIONS MAY VARY BY .25" DUE TO CASTING AND/OR FABRICATION VARIATIONS.
2: LARGEST MOTOR WIDTH.
3: FRAME REFERENCE: 12.500"/254//14.250"/256

4: CONDUIT BOX MAY BE LOCATED ON EITHER SIDE OF MOTOR. CONDUIT OPENINGS MAY BE LOCATED IN STEPS OF 180 DEGREES REGARDLESS OF LOCATION. STANDARD AS SHOWN WITH CONDUIT OPENING DOWN.
5: TOLERANCES SHOWN ARE IN INCHES ONLY.

07-2879/C

Nidec Motor Corporation
St. Louis, Missouri

INFORMATION DISCLOSED ON THIS DOCUMENT IS CONSIDERED PROPRIETARY AND SHALL NOT BE REPRODUCED OR DISCLOSED WITHOUT WRITTEN CONSENT OF NIDEC MOTOR CORPORATION



ISSUED BY
R. KING
APPROVED BY
J. O'BRIEN

IHP_DP_NMCA (MAR-2011) SOLIDEDGE