

## MODELS

### STR502

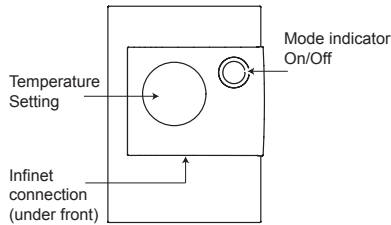

### STR504

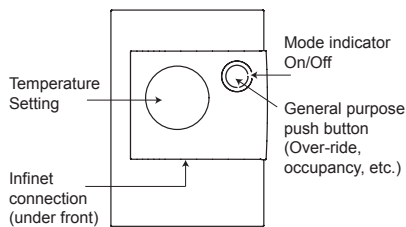

## REMOVING THE CORE

The core panel is attached to the base-plate using two hinges. Remove the core panel by pushing the bottom of the core panel upwards, then unhooking the core panel from the base-plate.

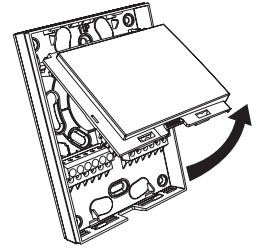

When the core has been turned upwards, the terminal blocks designation becomes visible:

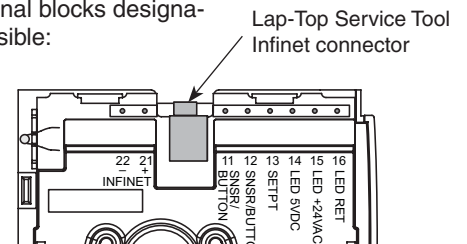

## ATTACHING/REMOVING THE FRONT

The front is attached to the base-plate using four clamps, two at the top of the front panel and two at the bottom.

When removing the front-panel use a screwdriver (or similar) and push gently to unhook the clamps at the top and bottom of the front panel.

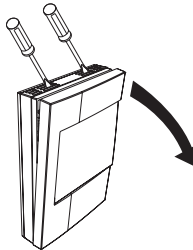

## MOUNTING, CABLES

To avoid base plate deformation, be careful when tightening the mounting screws.

Note that the enclosed screws are mainly intended for the US and Australian markets.

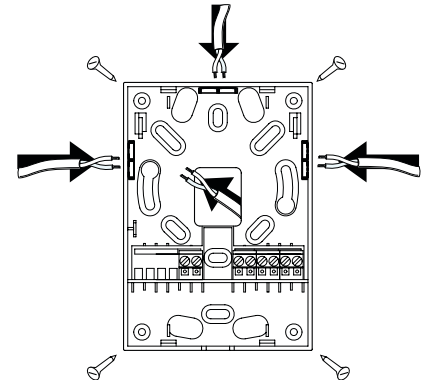

## CONNECTING

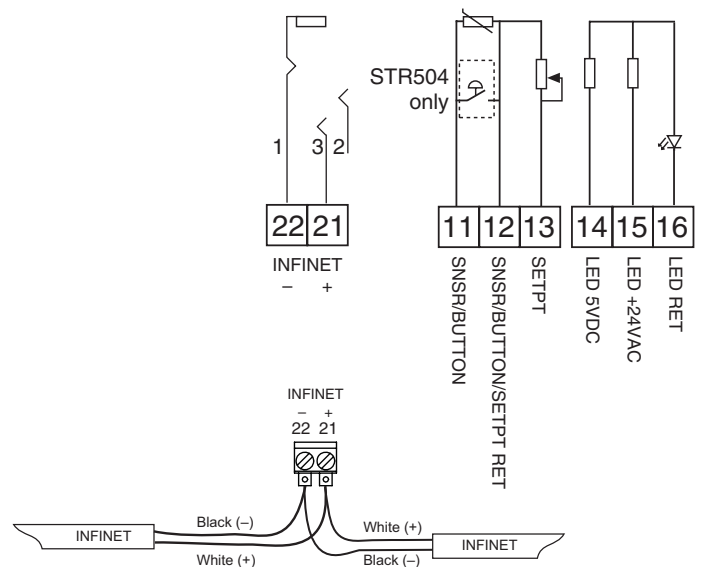
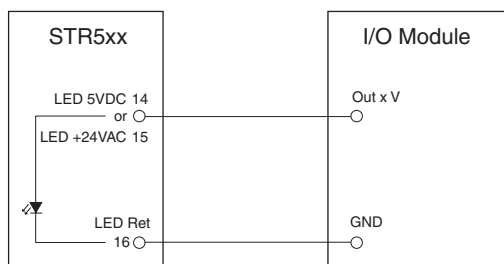
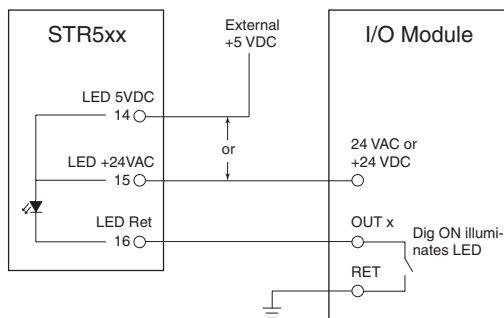

## Setpoint Adjustment Wheel

A variable resistor wheel is provided to act as a manual setpoint adjustment. To read its value, configure an Analog input. Connect the wheel orange wire to one of the controller's Analog IN terminals. The wheel shares its return signal with that of the thermistor.

The following function can be used to read the value of the wheel control on the STR5xx for setpoint adjustment. The function uses the ElecValue of the wheel (potentiometer) to return the setpoint. It works with 5, 10 or 8 volt input types. This function must be located in the controller to which the STR5xx is wired.

The *Plain English* code for the function is as shown below. In this example, the function object is named SP.

```
Arg 1 STR5xx      'the actual setpoint wheel (pot)
                  'input name
Arg 2 Lower      'temperature setpoint
Arg 3 Upper      'temperature setpoint
Arg 4 RefVolt    'the input type (5, 10 or 8 volt)

Numeric Vref, Rref, Rsens, V, MaxOhms, SetPt
MaxOhms = 10.13 'K ohms - Resistance between wheel
               'terminals when it's at the
               'clockwise end value. Adjust this
               'for field variations.

If RefVolt is 5 then
  Vref = 5.115
  Rref = 10
Else
  If RefVolt is 10 then
    Vref = 10
    Rref = 30.1
  Else
    Vref = 8.192
    Rref = 30.1
  Endif
Endif

If STR5xx ElecValue <= 0 then Return Upper
If STR5xx ElecValue >= Vref then Return Lower
V = (Vref/STR5xx ElecValue)
Rsens = (V * 0.2 - Rref - 0.2) / (1 - V)
SetPt = Lower + ((Rsens/MaxOhms) * (Upper - Lower))
SetPt = minimum(maximum(SetPt, Lower), Upper)
Return SetPt
```

For best accuracy, use a multimeter to measure the resistance between the terminals 12 and 13 on the STR5xx when the wheel is pushed all the way to its clockwise end value. Change the value of MaxOhms in the function to agree with your measured value.

Load the function into the controller and wire up the STR5xx. Create a voltage input for the wheel - this example calls it Wheel. Create a numeric setpoint such as STR5xxSP. Write a one line program which sets this numeric equal to the result of the function. In this example, the (looping) program line is: STR5xxSP = SP(Wheel, 69, 75,10)

Refer to the function's *Plain English* code above for a description of the arguments.

## Occupancy button on STR504

The over-ride push button is connected across the temperature sensor. To read the state of the button you must have configured the sensor input as a Temperature Input at the controller. Firmly pressing the button shorts the sensor which renders a temperature reading of above 150 °F (65.5 °C) at the input.

An occupancy button can be programmed as follows.

```
InitLine:
  RoomOccupied = Off
CheckTemp:
  If STR504_Room_Temp > 320 then
    RoomOccupied = On
    Goto CheckControl
  Endif
  Goto CheckTemp
CheckControl:
  If RoomOccupied then

    If heater_2 = Off then
      heater_2 = On
    Else
      heater_2 = Off
    Endif
  Endif
WaitNormal:
  If STR504_Room_Temp < 300 then
    Goto ClearTrigger
  Goto WaitNormal
ClearTrigger:
  RoomOccupied = Off
  Goto CheckTemp
```