

MOUNTING, CABLES

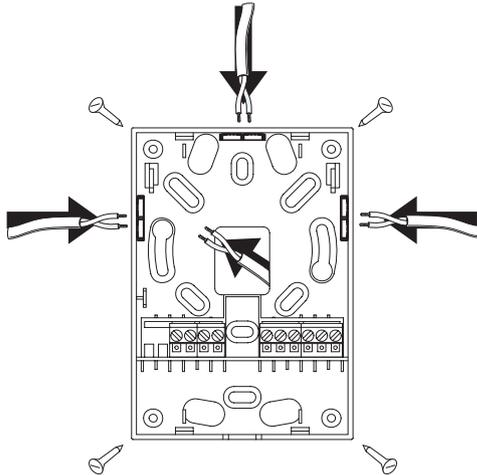

To avoid base-plate deformation, be careful when tightening the mounting screws. Note that the enclosed screws are mainly intended for the US and Australian markets.

CONNECTING

Connecting STR100 to a TAC Generic Controller

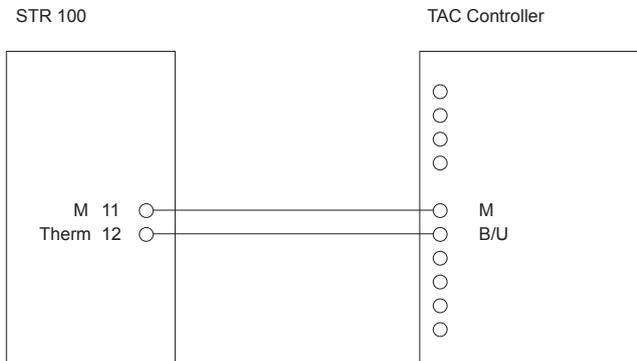

Connecting STR101-107 to a TAC Xenta 100 Controller

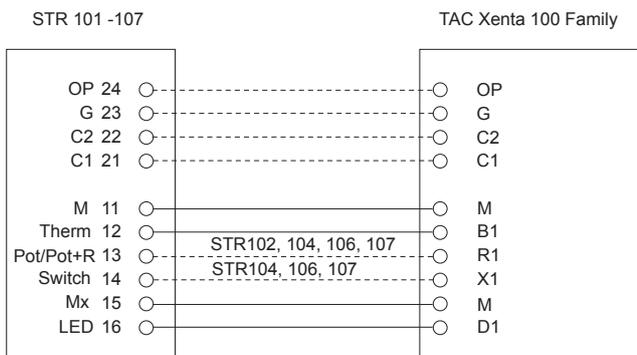

REMOVING THE CORE

The core panel is attached to the base-plate using two hinges. Remove the core panel by pushing the bottom of the core panel upwards, then unhinging the core panel from the base-plate.

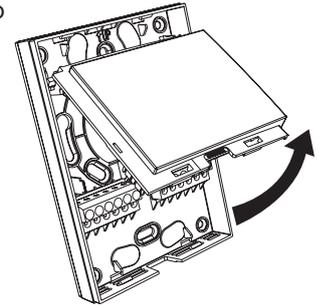

CONNECTING TO XENTA 200/300/400

Use an analog output set to 5V when connecting STR101-107 to the TAC Xenta 200/300/400 series of controllers.

Alternatively, use a digital output. If 24VAC is used, the temperature readings in the wall module will display an incorrect value when the LED is activated. There are two ways to correct this:

1. Make a -0.5 °C adjustment in the Menta application when the LED drive is active.
2. Add a 5 kΩ resistance (4.7 - 5,1 kΩ) ¼W in one of three possible positions (see drawing):
Between G and KC1
Between K1 and LED 16
Between Mx 15 and M.

The resistor must be placed outside the STR.

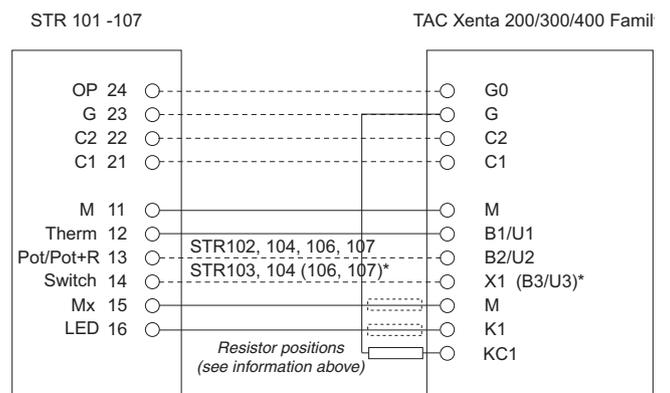

*STR103, 104: Connect to digital input, X or U.
STR106, 107: Connect to thermistor input (1.8k) B or U.

WIRING

Cable type Twisted pair, unshielded
Cable size Min 0.7 mm² (19 AWG)
Distance Max 30 m (100 Ft)

ATTACHING/REMOVING THE FRONT

The front is attached to the base-plate using four clamps, two at the top of the front panel and two at the bottom.

When removing the front-panel use a screwdriver (or similar) and push gently to unhook the clamps at the top and bottom of the front panel.

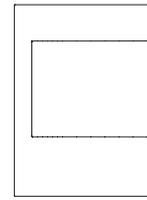
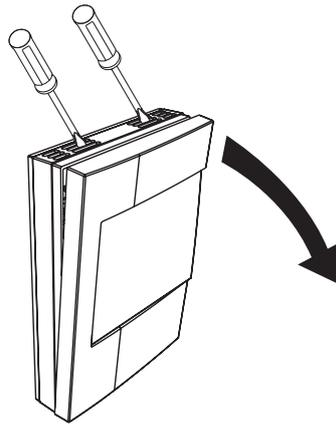

STR100

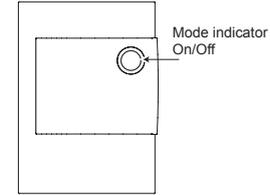

STR101

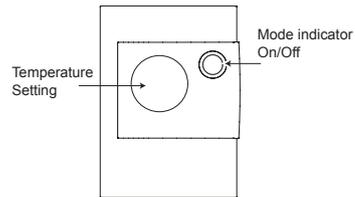

STR102

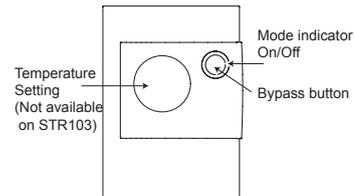

STR103/STR104

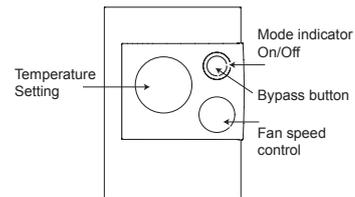

STR106/STR107

JUMPER POSITION

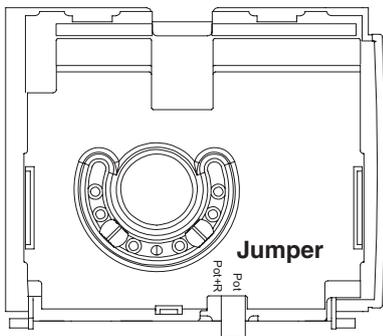

Rear view of core.

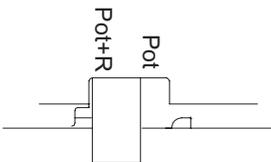

TAC Xenta 200, 300 and 400 series

Position of jumper when a TAC Xenta 200, 300 or 400 controller is used.

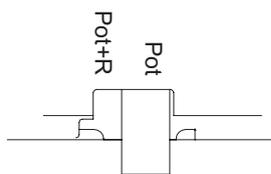

TAC Xenta 100 series
Position of toggle when a TAC Xenta 100 controller is used.

TEMPERATURE WHEEL

The temperature is controlled using the temperature setting wheel. The adjustment range on the temperature wheel may be set to the following limits:

- ± 1 °C (± 1.8 °F)
- ± 2 °C (± 3.6 °F)
- ± 3 °C (± 5.4 °F)
- ± 4 °C (± 7.2 °F)
- ± 5 °C (± 9 °F)

The adjust spacing is done using plastic keys on the back of the core.

STR106/107

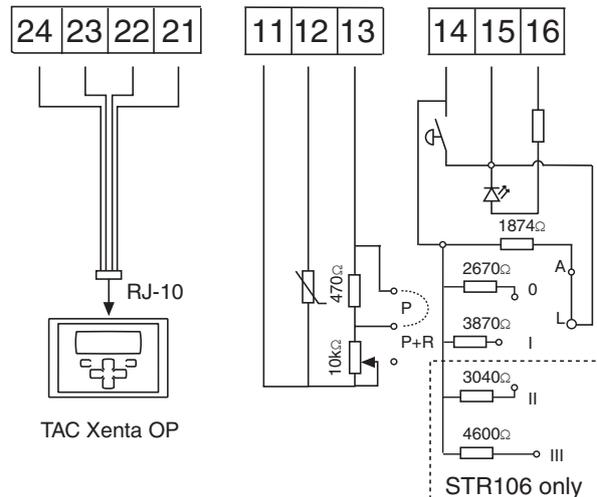

For more information visit
www.schneider-electric.com/buildings