

VTR8300 / VT8300 Series BACnet Integration

Terminal Equipment Controller

Commercial and Lodging HVAC Applications

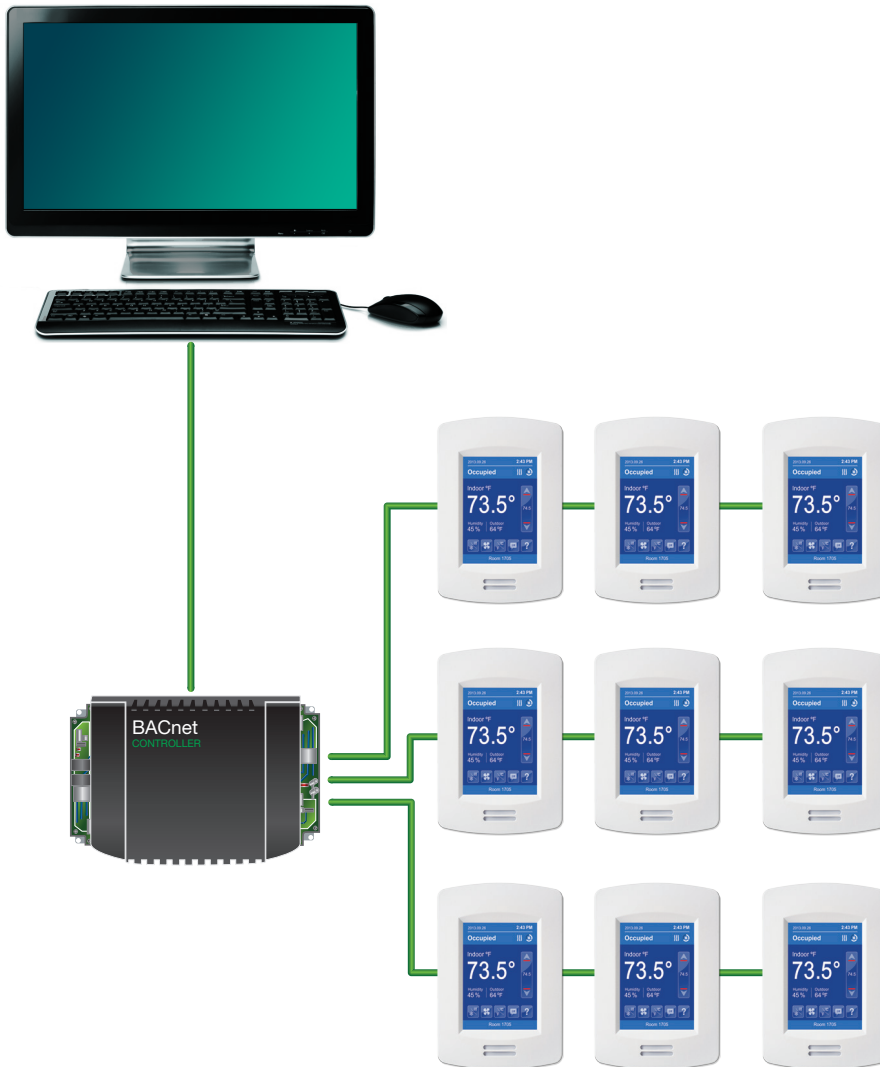

VTR8300 AND VT8300 SERIES PROTOCOL IMPLEMENTATION CONFORMANCE STATEMENT (PICS)

Vendor Name: Viconics Technologies

Supported BACnet® Services: The BACnet® communicating controller meets all requirements for designation as an Application Specific Controller (B-ASC). The BACnet controller supports the following BACnet Interoperability Building Blocks (BIBBs).

Application Service	Designation
Data Sharing – Read Property - B	DS-RP-B
Data Sharing – Read Property Multiple - B	DS-RPM-B
Data Sharing – Write Property - B	DS-WP-B
Data Sharing - Write Property Multiple Service - B	DS-WPM-B
Device Management - Time Synchronization - B	DM-TS-B
Device Management - Device Communication Control - B	DM-DCC-B
Device Management – Dynamic Device Binding - B	DM-DDB-B
Device Management – Dynamic Object Binding - B	DM-DOB-B

Note: The controller does not support segmented requests or responses.



VTR8300/VT8300



VC3000 Relay Pack

DEVICE OBJECTS TABLE

Object Name	Type and Instance	Object Property	Controller Parameter
VTR83xxA5x00B VT83xxU5x00B	Device	Object_Identifier Property 75 (R,W)	Unique ID number of a device on a network
		Object_Name Property 77 (R,W)	Unique name of a device on a network
		Model Name Property 70 (R)	Controller model number
		Firmware Revision Property 44 (R)	Current BACnet® firmware revision used by controller
		Protocol Version Property 98 (R)	Current BACnet® firmware protocol version Default is Version 1
		Protocol Revision Property 139 (R)	Current BACnet® firmware protocol revision Default is Version 2
		Max ADPU Length Property 62 (R)	Maximum ADPU Length accepted Default is 480
		ADPU Timeout Property 10 (R)	ADPU timeout value Default is 3000 ms
		Application- Software-Version Property 12 (R)	Controller base application software version Default is based on current released version
		Max_Master (R,W)	Maximum master devices allowed to be part of network. 0 to 127, default is 127
		Description Property 28 (R,W)	String of printable characters (Same as "Long Screen Message" CSV2)
		Location Property 58 (R,W)	String of printable characters (Same as "Short Screen Message" CSV1)
		Local Date Property 56 (R)	Indicates date to best of device knowledge
		Local Time Property 57 (R)	Indicated time of day best of the device knowledge

ANALOG OBJECT PROPERTIES

Object Type Read/Write Settings			Object Property	Controller Parameter
Input AI	Output AO	Values AV		
Read Only	Read Only	Read Only	Event State Property 36	Indicates if object has an active event state associated with it
Read Only	Read Only	Read Only	Object Identifier Property 75	Unique ID number of an object on a network
Read Only	Read Only	Read Only	Object Name Property 77	Unique name of an object on a network
Read Only	Read Only	Read Only	Object Type Property 79	Indicates membership in a particular object type class
Read / Write	Read / Write	Read / Write	Out of Service Property 81	Indicates whether (TRUE/FALSE) the physical input object represents is not in service
Read / Write*	Read / Write	Read / Write	Present Value Property 85	Contains values of all properties specified
N/A	Read Only	Read Only	Priority Array Property 87	Read-only array of prioritized values
Read Only	Read Only	Read Only	Reliability Property 103	Indicates if Present_Value is "reliable"
N/A	Read Only	Read / Write †	Relinquish Default Property 104	Default value used for Present_Value when values in Priority_Array have a NULL value
Read Only	Read Only	Read Only	Status Flags Property 111	Represents flags that indicate general health of life safety point object
Read Only	Read Only	Read Only	Units Property 177	Indicates measurement units of Present_Value
N/A	Read Only	N/A	Hight Limit Property 45	Specifies a limit Present_Value must exceed before an event is generated
N/A	Read Only	N/A	Low Limit Property 59	Specifies a limit Present_Value must fall below before an event is generated

N/A = Not Applicable, property not used for objects of that type

* The Present_Value is only writeable when Out_Of_Service is TRUE.

† Relinquish default is Read Only for AV100+

BINARY OBJECT PROPERTIES

Object Type Read/Write Settings			Object Property	Controller Parameter
Input BI	Output BO	Values BV		
Read Only	Read Only	Read Only	Active Text Property 4	Characterizes intended effect of the ACTIVE state of Present_Value property
Read Only	Read Only	Read Only	Event State Property 36	Indicates if object has an active event state associated with it
Read Only	Read Only	Read Only	Inactive Text Property 46	Characterizes intended effect of INACTIVE state of Present_Value property
Read Only	Read Only	Read Only	Object Identifier Property 75	Unique ID number of an object on a network
Read Only	Read Only	Read Only	Object Name Property 77	Unique name of an object on a network
Read Only	Read Only	Read Only	Object Type Property 79	Indicates membership in a particular object type class
Read / Write	Read / Write	Read / Write	Out of Service Property 81	Indicates whether (TRUE/FALSE) physical input object represents is not in service
Read Only	Read / Write	N/A	Polarity Property 84	Indicates relationship between physical state of input and Present_Value
Read / Write	Read / Write	Read / Write	Present Value Property 85	Contains values of all properties specified
Read Only	Read Only	Read Only	Priority Array Property 87	Read-only array of prioritized values
N/A	Read Only	Read Only	Relinquish Default Property 104	Default value to be used for Present_Value when values in Priority_Array have a NULL value
Read Only	Read Only	Read Only	Status Flags Property 111	Represents flags that indicate general health of life safety point object

N/A = Not Applicable, property not used for objects of that type

MULTISTATE OBJECT PROPERTIES

Object Type Read/Write Settings		Object Property	Controller Parameter
Inputs MSI	Values MV		
Read Only	Read Only	Event State Property 36	Indicates if object has an active event state associated with it
Read Only	Read Only	Number of States Property 74	Defines number of states Present_Value may have
Read Only	Read Only	Object Identifier Property 75	Unique ID number of an object on a network
Read Only	Read Only	Object Name Property 77	Unique name of an object on a network
Read Only	Read Only	Object Type Property 79	Indicates membership in a particular object type class
Read / Write	Read / Write	Out of Service Property 81	Indicates whether (TRUE/FALSE) physical input object represents is not in service
Read / Write*	Read / Write	Present Value Property 85	Contains values of all properties specified
N/A	Read Only	Priority Array Property 87	Indicates relationship between physical state of input and Present_Value
N/A	Read / Write	Relinquish Default Property 104	Default value used for Present_Value when values in Priority_Array have a NULL value
Read Only	Read Only	State Text Property 110	Represents descriptions of all possible states of Present_Value
Read Only	Read Only	Status Flags Property 111	Represents flags that indicate general health of life safety point object

N/A = Not Applicable, property not used for objects of that type

*The Present_Value is only writeable when Out_Of_Service is TRUE.

CSV PROPERTIES

Object Property	Read/Write	Controller Parameter
Object Identifier Property 75	Read Only	Unique ID number of an object on a network
Object Name Property 77	Read Only	Unique name of an object on a network
Object Type Property 79	Read Only	Indicates membership in a particular object type class
Present Value Property 85	Read / Write	Contains values of all properties specified
Status Flags Property 111	Read Only	Represents flags that indicate general health of life safety point object
Event State Property 36	Read Only	Indicates object has an active event state associated with it

PG OBJECT PROPERTIES

Read/Write	Object Property	Controller Parameter
Read / Write	Description Property 28	String of printable characters whose content is not restricted. Contains the LUA program script (max size = 480 bytes)
Read Only	Description Of Halt Property 29	Describes the reason why a program has been halted Text is also displayed in the HMI debug log
Read Only	Instance Of Property 48	Local name of the application program being executed by this process
Read Only	Object Identifier Property 75	Unique ID number of an object on a network
Read Only	Object Name Property 77	Unique name of an object on a network
Read Only	Object Type Property 79	Indicates membership in a particular object type class
Read Only	Out Of Service Property 81	Indicates whether (TRUE/FALSE) the process this object represents is not in service
Write Only	Program Change Property 90	Used to request changes to the operating state of the program. Writing to property affects all 10 PG objects
Read Only	Program State Property 92	Current logical state of all 10 PG objects executing application programs
Read Only	Reason For Halt Property 100	If program halts, this property reflects the reason for halt for all 10 PG objects
Read Only	Status Flags Property 111	Represents flags that indicate general health of life safety point object

CAL OBJECT PROPERTIES

Read/Write	Object Property	Controller Parameter
Read / Write	Date List Property 23	List of calendar entries.
Read Only	Object Identifier Property 75	Unique ID number of an object on a network
Read Only	Object Name Property 77	Unique name of an object on a network
Read Only	Object Type Property 79	Indicates membership in a particular object type class
Read Only	Present Value Property 85	This property is TRUE when current date matches an entry.

SCH OBJECT PROPERTIES

Read/Write	Object Property	Controller Parameter
Read Only	Effective Period Property 32	Range of dates within which the Schedule object is active. All dates are in range, so always Effective
Read / Write	Exception Schedule Property 38	Sequence of schedule actions that takes precedence over normal behavior on a specific day or days. By default, this property refers to the calendar.
Read Only	Object Identifier Property 75	Unique ID number of an object on a network
Read Only	Object Name Property 77	Unique name of an object on a network
Read Only	Object Type Property 79	Indicates membership in a particular object type class
Read / Write	Present Value Property 85	Contains the current value of the schedule (0:unoccupied, 1:occupied) Only writeable when Out Of Service is TRUE
Read / Write	Out Of Service Property 81	Indicates whether (TRUE/FALSE) the internal calculations of the schedule object are used to determine the value of the Present Value property
Read Only	Reliability Property 103	Indicates if Present Value is "reliable"
Read Only	Status Flags Property 111	Represents flags that indicate general health of life safety point object
Read / Write	Weekly Schedule Property 123	7 elements that describe the sequence of schedule actions for each day of the week.
Read Only	Schedule Default Property 174	Default value to be used when no other scheduled value is in effect. Always Unoccupied

VTR8300 AND VT8300 SERIES

Object Name	Type and Instance	VTR8300A5x00B	VTR8350A5x00B	VT8300U5x00B	VT8350U5x00B
User HMI	AV 2	√	√	√	√
Low Backlight	AV 3	√	√	√	√
Night Backlight	AV 4	√	√	√	√
Purge Sample Period	AV 5	√	√	√	√
Purge Open	AV 6	√	√	√	√
Calibrate Temperature Sensor	AV 7	√	√	√	√
Calibrate Humidity Sensor	AV 8		√		√
COM Address	AV 10	√	√	√	√
ZigBee PAN ID	AV 11	√	√	√	√
ZigBee channel	AV 12	√	√	√	√
ZigBee Short Address	AV 13	√	√	√	√
ZigBee IEEE Address	AV 14	√	√	√	√
Get from COM	AV 15	√	√	√	√
BACnet Stack Poll Rate	AV 16	√	√	√	√
Lua Parameter A	AV 25			√	√
Lua Parameter B	AV 26			√	√
Lua Parameter C	AV 27			√	√
Lua Parameter D	AV 28			√	√
Lua Parameter E	AV 29			√	√
Lua Parameter F	AV 30			√	√
Occupied Heat Setpoint	AV 39	√	√	√	√
Occupied Cool Setpoint	AV 40	√	√	√	√
Standby Heat Setpoint	AV 41	√	√	√	√
Standby Cool Setpoint	AV 42	√	√	√	√
Unoccupied Heat Setpoint	AV 43	√	√	√	√
Unoccupied Cool Setpoint	AV 44	√	√	√	√
Default Heating Setpoint	AV 45	√	√	√	√
Standby Differential	AV 46	√	√	√	√
Number of Pipes	AV 52	√	√	√	√
Main Password	AV 56	√	√	√	√
User Password	AV 57	√	√	√	√
Heating Setpoint Limit	AV 58	√	√	√	√
Cooling Setpoint Limit	AV 59	√	√	√	√
Temporary Occupancy Time	AV 62	√	√	√	√
Minimum Deadband	AV 63	√	√	√	√
Proportional Band	AV 65	√	√	√	√
Standby Time	AV 67	√	√	√	√
Unoccupied Time	AV 68	√	√	√	√

Object Name	Type and Instance	VTR8300A5x00B	VTR8350A5x00B	VT8300U5x00B	VT8350U5x00B
RH Setpoint	AV 71		√		√
Dehumidification Hysterisys	AV 72		√		√
Dehumidification Max Cooling	AV 73		√		√
Heating CPH	AV 84	√	√	√	√
Cooling CPH	AV 85	√	√		
Heating Demand Limit	AV 88	√	√	√	√
Cooling Demand Limit	AV 89	√	√	√	√
Floating Time	AV 90			√	√
Room Temperature	AV 100	√	√	√	√
Outdoor Temperature	AV 101	√	√	√	√
Room Humidity	AV 103		√		√
Supply Temperature	AV 102	√	√	√	√
UI 19 Changeover	AV 104	√	√	√	√
Remote Sensor Temperature	AV 105			√	√
PI Heating Demand	AO 21	√	√	√	√
PI Cooling Demand	AO 22	√	√	√	√
Pulsed Heating Demand	AO 90	√	√	√	√
UO 11 Analog Output	AO 123			√	√
UO 12 Analog Output	AO 124			√	√
UO 9 Analog Output	AO 125			√	√
UO 10 Analog Output	AO 126			√	√
Thermistor	AI 1	√	√	√	√
Light Sensor Level	AI 2	√	√	√	√
Thermistor Self Heating	AI 3	√	√	√	√
Relative Humidity Raw Value	AI 4	√	√	√	√
Rem. Sensor	AI 5			√	√
UI 23 Raw value	AI 7			√	√
UI 22 Raw Value	AI 8			√	√
UI 19 Raw value	AI 31			√	√
Wireless Zone 1 IEEE Address	AI 210			√	√
Wireless Zone 2 IEEE Address	AI 220			√	√
Wireless Zone 3 IEEE Address	AI 230			√	√
Wireless Zone 4 IEEE Address	AI 240			√	√
Wireless Zone 5 IEEE Address	AI 250			√	√
Wireless Zone 6 IEEE Address	AI 260			√	√
Wireless Zone 7 IEEE Address	AI 270			√	√
Wireless Zone 8 IEEE Address	AI 280			√	√
Wireless Zone 9 IEEE Address	AI 290			√	√

VTR8300 AND VT8300 SERIES

Object Name	Type and Instance	VTR8300A5x00B	VTR8350A5x00B	VT8300U5x00B	VT8350U5x00B
Wireless Zone 10 IEEE Address	AI 300			√	√
Door Contact Status	BV 1	√	√	√	√
Door Contact Installed	BV 2	√	√	√	√
Window Contact Status	BV 3	√	√	√	√
Window Contact Installed	BV 4	√	√	√	√
Low Battery Alarm	BV 5	√	√	√	√
Force High Backlight	BV 6	√	√	√	√
Display Long Screen Message	BV 7	√	√	√	√
Local Motion	BV 32	√	√	√	√
Window Alarm	BV 35	√	√	√	√
Filter Alarm	BV 36	√	√	√	√
Service Alarm	BV 37	√	√	√	√
Dehumidification Status	BV 38		√		√
Smart Recovery Status	BV 40			√	√
ZigBee PIR Sensor Installed	BV 200			√	√
ZigBee Sensor Motion	BV 201			√	√
UO 9 Binary Output	BO 93	√	√	√	√
UO 10 Binary Output	BO 94	√	√	√	√
High Speed Fan Output	BO 95	√	√	√	√
Medium Speed Fan Output	BO 96	√	√	√	√
Low Speed Fan Output	BO 97	√	√	√	√
BO8 Auxiliary Output	BO 98			√	√
UO 11 Binary Output	BO 101			√	√
UO 12 Binary Output	BO 102			√	√
BI 1 / UI 16 Status*	BI 29	√	√	√	√
BI 2 / UI 17 Status*	BI 30	√	√	√	√
RUI 1 / UI 19 Status*	BI 91	√	√	√	√
RBI 2 Status	BI 92	√	√	√	√
Short Screen Message	CSV 1	√	√	√	√
Long Screen Message	CSV 2	√	√	√	√
Long message background color	MV 1	√	√	√	√
HMI Colour	MV 2	√	√	√	√
Main Display	MV 3	√	√	√	√
Display Language	MV 4	√	√	√	√
Time Format	MV 5			√	√
Network Units	MV 6	√	√	√	√
Network Language	MV 7	√	√	√	√
BACnet Baud Rate	MV 8	√	√	√	√

Object Name	Type and Instance	VTR8300A5x00B	VTR8350A5x00B	VT8300U5x00B	VT8350U5x00B
No Activity Sleep Mode	MV 9	√	√	√	√
Occupancy Command	MV 10	√	√	√	√
Standby Mode	MV 11	√	√	√	√
Dehumidification Lockout	MV 13		√		√
Sequence of Operation	MV 15	√	√	√	√
System Mode	MV 16	√	√	√	√
Fan Mode	MV 17	√	√	√	√
Use Standby Screen	MV 32	√	√	√	√
BI 1 / UI 16 Configuration*	MV 46	√	√	√	√
BI 2 / UI 17 Configuration*	MV 47	√	√	√	√
UI 19 Configuration	MV 49			√	√
Auto Mode Enable	MV 50	√	√	√	√
Temperature Scale	MV 51	√	√	√	√
Fan Sequence	MV 57	√	√	√	√
Setpoint Function	MV 58			√	√
Auto Fan Function	MV 66	√	√	√	√
Room Humidity Setpoint	MV 70		√		√
Enable Smart Recovery	MV 71			√	√
Schedule Menu	MV 73			√	√
Control Type	MV 81			√	√
RUI 1 Configuration	MV 82	√	√		
RBI 2 Configuration	MV 83	√	√	√	√
Heating Valve	MV 86	√	√	√	√
Cooling Valve	MV 87	√	√	√	√
Pulsed Heating	MV 90	√	√	√	√
BO8 Aux Output Time Base	MV 91			√	√
BO8 Aux Output configuration	MV 92			√	√
DA / RA	MV 94			√	√
Fan Control	MV 95	√	√	√	√
UO 9 Configuration	MV 96			√	√
UO 10 Configuration	MV 97			√	√
UO 11 Configuration	MV 98			√	√
UO 12 Configuration	MV 99			√	√
French	MV 101			√	√
Spanish	MV 102			√	√
Chinese	MV 103			√	√
Russian	MV 104			√	√
Occupancy Source	MV 110			√	√

* Entry before slash refers to VTR83XX models, entry after slash refers to VT83XX models

VTR8300 AND VT8300 SERIES

Object Name	Type and Instance	VTR8300AxBxx	VTR8350AxBxx	VT8300UxBxx	VT8350UxBxx
Mode button	MV 111			√	√
Custom button icon	MV 114	√	√	√	√
Custom button behaviour	MV 115	√	√	√	√
Arabic	MV 120	√	√	√	√
Bulgarian	MV 121	√	√	√	√
Czech	MV 122	√	√	√	√
Danish	MV 123	√	√	√	√
Dutch	MV 124	√	√	√	√
Finnish	MV 125	√	√	√	√
German	MV 126	√	√	√	√
Hungarian	MV 127	√	√	√	√
Indonesian	MV 128	√	√	√	√
Italian	MV 129	√	√	√	√
Norwegian	MV 130	√	√	√	√
Polish	MV 131	√	√	√	√
Portuguese	MV 132	√	√	√	√
Slovak	MV 133	√	√	√	√
Swedish	MV 134	√	√	√	√
Turkish	MV 135	√	√	√	√
Wireless Zone 1 Set Function	MV 210			√	√
Wireless Zone 2 Set Function	MV 220			√	√
Wireless Zone 3 Set Function	MV 230			√	√
Wireless Zone 4 Set Function	MV 240			√	√
Wireless Zone 5 Set Function	MV 250			√	√
Wireless Zone 6 Set Function	MV 260			√	√
Wireless Zone 7 Set Function	MV 270			√	√
Wireless Zone 8 Set Function	MV 280			√	√
Wireless Zone 9 Set Function	MV 290			√	√
Wireless Zone 10 Set Function	MV 300			√	√
BACnet Status	MI 1	√	√	√	√
ZigBee Status	MI 2	√	√	√	√
Effective Occupancy	MI 33	√	√	√	√
Wireless Zone 1 Status	MI 210			√	√
Wireless Zone 1 Battery	MI 211			√	√
Wireless Zone 1 Paired	MI 212			√	√
Wireless Zone 2 Status	MI 220			√	√
Wireless Zone 2 Battery	MI 221			√	√
Wireless Zone 2 Paired	MI 222			√	√

Object Name	Type and Instance	VTR8300AxBxx	VTR8350AxBxx	VT8300UxBxx	VT8350UxBxx
Wireless Zone 3 Status	MI 230			√	√
Wireless Zone 3 Battery	MI 231			√	√
Wireless Zone 3 Paired	MI 232			√	√
Wireless Zone 4 Status	MI 240			√	√
Wireless Zone 4 Battery	MI 241			√	√
Wireless Zone 4 Paired	MI 242			√	√
Wireless Zone 5 Status	MI 250			√	√
Wireless Zone 5 Battery	MI 251			√	√
Wireless Zone 5 Paired	MI 252			√	√
Wireless Zone 6 Status	MI 260			√	√
Wireless Zone 6 Battery	MI 261			√	√
Wireless Zone 6 Paired	MI 262			√	√
Wireless Zone 7 Status	MI 270			√	√
Wireless Zone 7 Battery	MI 271			√	√
Wireless Zone 7 Paired	MI 272			√	√
Wireless Zone 8 Status	MI 280			√	√
Wireless Zone 8 Battery	MI 281			√	√
Wireless Zone 8 Paired	MI 282			√	√
Wireless Zone 9 Status	MI 290			√	√
Wireless Zone 9 Battery	MI 291			√	√
Wireless Zone 9 Paired	MI 292			√	√
Wireless Zone 10 Status	MI 300			√	√
Wireless Zone 10 Battery	MI 301			√	√
Wireless Zone 10 Paired	MI 302			√	√
Lua Program 1	PG 1			√	√
Lua Program 2	PG 2			√	√
Lua Program 3	PG 3			√	√
Lua Program 4	PG 4			√	√
Lua Program 5	PG 5			√	√
Lua Program 6	PG 6			√	√
Lua Program 7	PG 7			√	√
Lua Program 8	PG 8			√	√
Lua Program 9	PG 9			√	√
Lua Program 10	PG 10			√	√
Schedule	SCH 1			√	√
Calendar	CAL 1			√	√

PROPERTY VALUE RANGE RESTRICTIONS FOR AV OBJECTS

Object name	Object Type	Instance	Minimum Range Value	Maximum Range Value	Default Value
User HMI	AV	2	0	11	0
Low Backlight	AV	3	0%	100%	60%
Night Backlight	AV	4	0%	100%	5%
Calibrate Temperature Sensor	AV	7	-	5°F(2.5°C)	0°F (0°C)
Calibrate Humidity Sensor	AV	8	-15%	15%	0%
COM Address	AV	10	0	254	254
ZigBee PAN ID	AV	11	0	1000	0
ZigBee channel	AV	12	0	25	10
ZigBee Short Address	AV	13	0	32767	0
ZigBee IEEE Address	AV	14	0	32767	0
Get from COM	AV	15	0	254	0
BACnet Stack Poll Rate	AV	16	1	5	4
Lua Parameter A	AV	25	-32768	32767	0
Lua Parameter B	AV	26	-32768	32767	0
Lua Parameter C	AV	27	-32768	32767	0
Lua Parameter D	AV	28	-32768	32767	0
Lua Parameter E	AV	29	-32768	32767	0
Lua Parameter F	AV	30	-32768	32767	0
Occupied Heat Setpoint	AV	39	40°F (4.5°C)	90°F (32°C)	72°F (22°C)
Occupied Cool Setpoint	AV	40	54°F (12°C)	100°F (37.5°C)	75°F (24°C)
Standby Heat Setpoint	AV	41	40°F (4.5°C)	90°F (32°C)	69°F (21°C)
Standby Cool Setpoint	AV	42	54°F (12°C)	100°F (37.5°C)	78°F (26°C)
Unoccupied Heat Setpoint	AV	43	40°F (4.5°C)	90°F (32°C)	62°F (16.5°C)
Unoccupied Cooling Setpoint	AV	44	54°F (12°C)	100°F (37.5°C)	80°F (26.5°C)
Default Heating Setpoint	AV	45	65°F (18°C)	80°F (26.5°C)	72°F (22°C)
Standby Temperature Differential	AV	46	10°F (5.5°C)	50°F (28°C)	40°F (22°C)
Number of Pipes	AV	52	2	4	2
Main Password	AV	56	0	9999	N/A
User Password	AV	57	0	9999	0
Heating Setpoint Limit	AV	58	40°F (4.5°C)	90°F (32°C)	90°F (32°C)
Cooling Setpoint Limit	AV	59	54°F (12°C)	100°F (37.5°C)	54°F (12°C)
Temporary Occupied Time	AV	62	0H	24H	2H
Min. Deadband	AV	63	2°F (1°C)	5°F (2.5°C)	2°F (1°C)

PROPERTY VALUE RANGE RESTRICTIONS FOR AV OBJECTS

Object Name	Object Type	Instance	Minimum Range Value	Maximum Range Value	Default Value
Proportional Band	AV	65	3°F (1.2°C)	10°F (5.6°C)	3°F (1.2°C)
Standby time	AV	67	5H	24H	5H
Unoccupied Time	AV	68	0H	24H	0H
Room Humidity Setpoint	AV	71	30%	95%	50%
Dehumidification Hysteresis	AV	72	2%	20%	5%
Dehumidification Max Cooling	AV	73	20%	100%	100%
Heating CPH	AV	84	3	8	4
Cooling CPH	AV	85	3	8	4
Heating Demand Limit	AV	88	0%	100%	0%
Cooling Demand Limit	AV	89	0%	100%	0%
Floating Time	AV	90	5	90	15
Room Temperature	AV	100	-40°F (-40°C)	122°F (50°C)	N/A
Outdoor Temperature	AV	101	-40°F (-40°C)	122°F (50°C)	N/A
Supply Temperature	AV	102	-40°F (-40°C)	122°F (50°C)	N/A
Room Humidity	AV	103	5%	95%	N/A
RUI Temperature	AV	104	-40°F (-40°C)	122°F (50°C)	N/A
Remote Sensor temp	AV	105	-40°F (-40°C)	122°F (50°C)	N/A

PROPERTY VALUE RANGE RESTRICTIONS FOR AO OBJECTS

Object Name	Object Type	Instance	Minimum Range Value	Maximum Range Value	Default Value
PI Heating Demand	AO	21	0%	100%	N/A
PI Cooling Demand	AO	22	0%	100%	N/A
Pulsed Heating Demand	AO	90	0%	100%	N/A
UO 11 Analog Output	AO	123	0	100	0
UO 12 Analog Output	AO	124	0	100	0
UO 9 Analog Output	AO	125	0	100	0
UO 10 Analog Output	AO	126	0	100	0

PROPERTY VALUE RANGE RESTRICTIONS FOR AI OBJECTS

Object Name	Object Type	Instance	Minimum Range Value	Maximum Range Value	Default Value
Thermistor	AI	1	-400	1220	0
Light Sensor Level	AI	2	0	30000	N/A
Thermistor Self Heating	AI	3	-400	1220	0
Relative Humidity Raw Value	AI	4	200	800	0
Rem. Sensor	AI	5	0	4095	0
UI 23 Raw value	AI	7	0	4095	0
UI 22 Raw Value	AI	8	0	4095	0
UI 19 Raw value	AI	31	0	4095	0
Wireless Zone 1 IEEE address	AI	210	0	32767	0
Wireless Zone 2 IEEE address	AI	220	0	32767	0
Wireless Zone 3 IEEE address	AI	230	0	32767	0
Wireless Zone 4 IEEE address	AI	240	0	32767	0
Wireless Zone 5 IEEE address	AI	250	0	32767	0
Wireless Zone 6 IEEE address	AI	260	0	32767	0
Wireless Zone 7 IEEE address	AI	270	0	32767	0
Wireless Zone 8 IEEE address	AI	280	0	32767	0
Wireless Zone 9 IEEE address	AI	290	0	32767	0
Wireless Zone 10 IEEE address	AI	300	0	32767	0

PROPERTY VALUE RANGE RESTRICTIONS FOR BV OBJECTS

Object Name	Object Type	Instance	Minimum Range Value	Maximum Range Value	Default Value
Door Contact Status	BV	1	Closed	Open	Closed
Door Contact Installed	BV	2	No	Yes	No
Window Contact Status	BV	3	Closed	Opened	Closed
Window Contact Installed	BV	4	No	Yes	No
Low Battery Alarm	BV	5	Off	On	Off
Force High Backlight	BV	6	Off	On	Off
Display Long Screen Message	BV	7	Off	On	No
Local Motion	BV	32	On	Off	On
Window Alarm	BV	35	Off	On	Off
Filter Alarm	BV	36	Off	On	Off
Service alarm	BV	37	Off	On	Off
Dehumidification Status	BV	38	Off	On	Off
Smart Recovery Status	BV	40	Off	On	Off
ZigBee PIR Sensor Installed	BV	200	Off	On	Off
Zigbee Sensor Motion	BV	201	Off	On	Off

PROPERTY VALUE RANGE RESTRICTIONS FOR BO OBJECTS

Object Name	Object Type	Instance	Minimum Range Value	Maximum Range Value	Default Value
UO 9 Binary Output	BO	93	Off	On	Off
UO 10 Binary Output	BO	94	Off	On	Off
High Speed Fan Output	BO	95	Off	On	Off
Medium Fan Speed Output	BO	96	Off	On	Off
Low Speed Fan Output	BO	97	Off	On	Off
BO 8 Auxiliary Binary Output	BO	98	Off	On	Off
UO 11 Binary Output	BO	101	Off	On	Off
UO 12 Binary Output	BO	102	Off	On	Off

PROPERTY VALUE RANGE RESTRICTIONS FOR BI OBJECTS

Object Name	Object Type	Instance	Minimum Range Value	Maximum Range Value	Default Value
BI 1 / UI 16 Binary Input	BI	29	Deactivated	Activated	Deactivated
BI 2 / UI 17 Binary Input	BI	30	Deactivated	Activated	Deactivated
RUI 1 / UI 19 Binary Input	BI	91	Deactivated	Activated	Deactivated
RBI 2 Status	BI	92	Deactivated	Activated	Deactivated

PROPERTY VALUE RANGE RESTRICTIONS FOR MV OBJECTS

Object Name	Object Type	Instance	Index	Text	Default Value
Long Message Background Colour	MV	1	1	White	White
			2	Green	
			3	Blue	
			4	Grey	
			5	Dark Grey	
			6	Default	
			7	Red	
HMI Colour	MV	2	1	White	Green
			2	Green	
			3	Blue	
			4	Grey	
			5	Dark Grey	
Main Display	MV	3	1	Temperature	Temperature
			2	Setpoint	

PROPERTY VALUE RANGE RESTRICTIONS FOR MV OBJECTS

Object Name	Object Type	Instance	Index	Text	Default Value
Display Language	MV	4	1	English	English
			2	French	
			3	Spanish	
			4	Chinese	
			5	Russian	
			6	Arabic	
			7	Bulgarian	
			8	Czech	
			9	Danish	
			10	Dutch	
			11	Finnish	
			12	German	
			13	Hungarian	
			14	Indonesian	
			15	Italian	
			16	Norwegian	
			17	Polish	
			18	Portuguese	
			19	Slovak	
			20	Swedish	
			21	Turkish	
Time Format	MV	5	1	AM-PM	AM-PM
			2	24 Hours	
Network Units	MV	6	1	SI	SI
			2	Imperial	
Network Language	MV	7	1	English	English
			2	French	
			3	Spanish	
BACnet Baud Rate	MV	8	1	9600	Auto
			2	19200	
			3	38400	
			4	57600	
			5	76800	
			6	115200	
			7	Auto	
No Activity Sleep Mode	MV	9	1	Disabled	Disabled
			2	Enabled	
Occupancy Command	MV	10	1	Local Occupancy	Local Occupancy
			2	Occupied	
			3	Unoccupied	

PROPERTY VALUE RANGE RESTRICTIONS FOR MV OBJECTS

Object Name	Object Type	Instance	Index	Text	Default Value
Standby Mode	MV	11	1	Absolute	Absolute
			2	Offset	
Dehumidification Lockout	MV	13	1	Disabled	Enabled
			2	Enabled	
Sequence of Operation	MV	15	1	Cooling Only	Heating Only
			2	Heating Only	
			3	Cooling with Electric Reheat	
			4	Heating with Electric Reheat	
			5	Cooling / Heating	
			6	Cooling / Heating, with Electric Reheat	
System Mode	MV	16	1	Off	Heat
			2	Auto	
			3	Cool	
			4	Heat	
Fan Mode	MV	17	1	Low	Auto
			2	Med	
			3	High	
			4	Auto	
			5	On	
Use Standby Screen	MV	32	1	No	No
			2	Yes	
BI 1 / UI 16 Configuration	MV	46	1	None	None
			2	Rem NSB	
			3	Motion NO	
			4	Motion NC	
			5	Window	
BI 2 / UI 17 Configuration	MV	47	1	None	None
			2	Door Dry	
			3	Override	
Auto Mode Enable	MV	50	1	Disabled	Enabled
			2	Enabled	
Temperature Scale	MV	51	1	°C	°C
			2	°F	
Fan Menu Sequence	MV	57	1	Low-Med-High	On-Auto
			2	Low-High	
			3	Low-Med-High-Auto	
			4	Low-High-Auto	
			5	On-Auto	

PROPERTY VALUE RANGE RESTRICTIONS FOR MV OBJECTS

Object Name	Object Type	Instance	Index	Text	Default Value
Setpoint Function	MV	58	1	Dual Stp	Dual Stp
			2	Attach Stp	
Auto Fan Function	MV	66	1	AS	AS
			2	AS / AD	
Room Humidity Display	MV	70	1	Disabled	Disabled
			2	Enabled	
Enable Smart Recovery	MV	71	1	Off	Off
			2	On	
Schedule Menu	MV	73	1	Disabled	Disabled
			2	Enabled	
			3	Dis.no.clk	
			4	En.no.clk	
Control Type	MV	81	1	On / Off	Floating
			2	Floating	
			3	Analog	
RUI 1 Configuration	MV	82	1	None	None
			2	Filter	
			3	Service	
			4	COC/NH	
			5	COC/NC	
			6	COS	
RBI 2 Configuration	MV	83	1	None	None
			2	Filter	
			3	Service	
Heating Valve	MV	86	1	NO	Normally Closed
			2	NC	
Cooling Valve	MV	87	1	NO	Normally Closed
			2	NC	
Pulsed Heating	MV	90	1	Off	Off
			2	On	
			3	Occupancy Output	
BO8 Aux Output Time Base	MV	91	1	15 min.	15 min.
			2	10 sec.	
BO8 Aux Output Configuration	MV	92	1	Not Used	Not Used
			2	Aux NO	
			3	Aux NC	
			4	Aux F&NO	
			5	Aux F&NC	
Action	MV	94	1	DA	DA
			2	RA	

PROPERTY VALUE RANGE RESTRICTIONS FOR MV OBJECTS

Object Name	Object Type	Instance	Index	Text	Default Value
Fan Control	MV	95	1	On	On
			2	Off-Auto	
			3	Off-All	
UO 9 Configuration	MV	96	1	Analog	Binary
			2	Binary	
UO 10 Configuration	MV	97	1	Analog	Binary
			2	Binary	
UO 11 Configuration	MV	98	1	Analog	Binary
			2	Binary	
UO 12 Configuration	MV	99	1	Analog	Binary
			2	Binary	
French	MV	101	1	Disabled	Enabled
			2	Enabled	
Spanish	MV	102	1	Disabled	Enabled
			2	Enabled	
Chinese	MV	103	1	Disabled	Enabled
			2	Enabled	
Russian	MV	104	1	Disabled	Enabled
			2	Enabled	
Occupancy Source	MV	110	1	Motion	Motion
			2	Schedule	
Mode button	MV	111	1	Normal	Normal
			2	Off-Auto	
Custom button icon	MV	114	1	Default Button	Default Button
			2	No Button	
			3	System Mode Heat/Cool	
			4	System Mode On/Off	
			5	Fan Mode	
			6	Override Button	
			7	Units Button	
			8	Help Button	
			9	Language Button	
			10	Schedule Button	
			11	Lighting Button	
			12	Blind Button	
			13	Lamp Button	
			14	Energy Button	
			15	Make Room Button	
			16	Setting Button	
			17	Timer Button	

PROPERTY VALUE RANGE RESTRICTIONS FOR MV OBJECTS

Object Name	Object Type	Instance	Index	Text	Default Value
Custom button behaviour	MV	115	1	Default Function	Default Function
			2	No Function	
			3	System Mode Function	
			4	Fan Function	
			5	Override Function	
			6	Schedule Function	
			7	Units Function	
			8	Help Function	
			9	Language Function	
			10	Configuration Function	
			11	Custom Function	
			12	Standby Function	
Arabic	MV	120	1	Disabled	Disabled
			2	Enabled	
Bulgarian	MV	121	1	Disabled	Disabled
			2	Enabled	
Czech	MV	122	1	Disabled	Disabled
			2	Enabled	
Danish	MV	123	1	Disabled	Disabled
			2	Enabled	
Dutch	MV	124	1	Disabled	Disabled
			2	Enabled	
Finnish	MV	125	1	Disabled	Disabled
			2	Enabled	
German	MV	126	1	Disabled	Disabled
			2	Enabled	
Hungarian	MV	127	1	Disabled	Disabled
			2	Enabled	
Indonesian	MV	128	1	Disabled	Disabled
			2	Enabled	
Italian	MV	129	1	Disabled	Disabled
			2	Enabled	
Norwegian	MV	130	1	Disabled	Disabled
			2	Enabled	
Polish	MV	131	1	Disabled	Disabled
			2	Enabled	
Portuguese	MV	132	1	Disabled	Disabled
			2	Enabled	
Slovak	MV	133	1	Disabled	Disabled
			2	Enabled	

PROPERTY VALUE RANGE RESTRICTIONS FOR MV OBJECTS

Object Name	Object Type	Instance	Index	Text	Default Value
Swedish	MV	134	1	Disabled	Disabled
			2	Enabled	
Turkish	MV	135	1	Disabled	Disabled
			2	Enabled	
Wireless Zone 1 Set Function	MV	210	1	None	None
			2	Window	
			3	Door	
			4	Motion	
			5	Status	
			6	Remove	
Wireless Zone 2 Set Function	MV	220	1	None	None
			2	Window	
			3	Door	
			4	Motion	
			5	Status	
			6	Remove	
Wireless Zone 3 Set Function	MV	230	1	None	None
			2	Window	
			3	Door	
			4	Motion	
			5	Status	
			6	Remove	
Wireless Zone 4 Set Function	MV	240	1	None	None
			2	Window	
			3	Door	
			4	Motion	
			5	Status	
			6	Remove	
Wireless Zone 5 Set Function	MV	250	1	None	None
			2	Window	
			3	Door	
			4	Motion	
			5	Status	
			6	Remove	
Wireless Zone 6 Set Function	MV	260	1	None	None
			2	Window	
			3	Door	
			4	Motion	
			5	Status	
			6	Remove	

PROPERTY VALUE RANGE RESTRICTIONS FOR MV OBJECTS

Object Name	Object Type	Instance	Index	Text	Default Value
Wireless Zone 7 Set Function	MV	270	1	None	None
			2	Window	
			3	Door	
			4	Motion	
			5	Status	
			6	Remove	
Wireless Zone 8 Set Function	MV	280	1	None	None
			2	Window	
			3	Door	
			4	Motion	
			5	Status	
			6	Remove	
Wireless Zone 9 Set Function	MV	290	1	None	None
			2	Window	
			3	Door	
			4	Motion	
			5	Status	
			6	Remove	
Wireless Zone 10 Set Function	MV	300	1	None	None
			2	Window	
			3	Door	
			4	Motion	
			5	Status	
			6	Remove	

PROPERTY VALUE RANGE RESTRICTIONS FOR MI OBJECTS

Object Name	Object Type	Instance	Index	Text	Default Value
BACnet Status	MI	1	1	Offline	Offline
			2	Online	
ZigBee Status	MI	2	1	Not Detected	N/A
			2	Power On	
			3	No Network	
			4	Joined	
			5	Online	
Effective Occupancy	MI	33	1	Occupied	Occupied
			2	Unoccupied	
			3	Override	
			4	Standby	

PROPERTY VALUE RANGE RESTRICTIONS FOR MI OBJECTS

Object Name	Object Type	Instance	Index	Text	Default Value
Wireless Zone 1 Status	MI	210	1	None	None
			2	Closed	
			3	Opened	
			4	Motion	
			5	No Motion	
Wireless Zone 1 Battery	MI	211	1	None	None
			2	Normal	
			3	Low	
Wireless Zone 1 Paired	MI	212	1	No	No
			2	Yes	
			3	Invalid	
Wireless Zone 2 Status	MI	220	1	None	None
			2	Closed	
			3	Opened	
			4	Motion	
			5	No Motion	
Wireless Zone 2 Battery	MI	221	1	None	None
			2	Normal	
			3	Low	
Wireless Zone 2 Paired	MI	222	1	No	No
			2	Yes	
			3	Invalid	
Wireless Zone 3 Status	MI	230	1	None	None
			2	Closed	
			3	Opened	
			4	Motion	
			5	No Motion	
Wireless Zone 3 Battery	MI	231	1	None	None
			2	Normal	
			3	Low	
Wireless Zone 3 Paired	MI	232	1	No	No
			2	Yes	
			3	Invalid	
Wireless Zone 4 Status	MI	240	1	None	None
			2	Closed	
			3	Opened	
			4	Motion	
			5	No Motion	

PROPERTY VALUE RANGE RESTRICTIONS FOR MI OBJECTS

Object Name	Object Type	Instance	Index	Text	Default Value
Wireless Zone 4 Battery	MI	241	1	None	None
			2	Normal	
			3	Low	
Wireless Zone 4 Paired	MI	242	1	No	No
			2	Yes	
			3	Invalid	
Wireless Zone 5 Status	MI	250	1	None	None
			2	Closed	
			3	Opened	
			4	Motion	
			5	No Motion	
Wireless Zone 5 Battery	MI	251	1	None	None
			2	Normal	
			3	Low	
Wireless Zone 5 Paired	MI	252	1	No	No
			2	Yes	
			3	Invalid	
Wireless Zone 6 Status	MI	260	1	None	None
			2	Closed	
			3	Opened	
			4	Motion	
			5	No Motion	
Wireless Zone 6 Battery	MI	261	1	None	None
			2	Normal	
			3	Low	
Wireless Zone 6 Paired	MI	262	1	No	No
			2	Yes	
			3	Invalid	
Wireless Zone 7 Status	MI	270	1	None	None
			2	Closed	
			3	Opened	
			4	Motion	
			5	No Motion	
Wireless Zone 7 Battery	MI	271	1	None	None
			2	Normal	
			3	Low	
Wireless Zone 7 Paired	MI	272	1	No	No
			2	Yes	
			3	Invalid	

PROPERTY VALUE RANGE RESTRICTIONS FOR MI OBJECTS

Object Name	Object Type	Instance	Index	Text	Default Value
Wireless Zone 8 Status	MI	280	1	None	None
			2	Closed	
			3	Opened	
			4	Motion	
			5	No Motion	
Wireless Zone 8 Battery	MI	281	1	None	None
			2	Normal	
			3	Low	
Wireless Zone 8 Paired	MI	282	1	No	No
			2	Yes	
			3	Invalid	
Wireless Zone 9 Status	MI	290	1	None	None
			2	Closed	
			3	Opened	
			4	Motion	
			5	No Motion	
Wireless Zone 9 Battery	MI	291	1	None	None
			2	Normal	
			3	Low	
Wireless Zone 9 Paired	MI	292	1	No	No
			2	Yes	
			3	Invalid	
Wireless Zone 10 Status	MI	300	1	None	None
			2	Closed	
			3	Opened	
			4	Motion	
			5	No Motion	
Wireless Zone 10 Battery	MI	301	1	None	None
			2	Normal	
			3	Low	
Wireless Zone 10 Paired	MI	302	1	No	No
			2	Yes	
			3	Invalid	

PROPERTY VALUE RANGE RESTRICTIONS FOR CSV OBJECTS

Object Name	Object Type	Instance	Parameters
Short Screen Message	CSV	1	String of printable characters. (Same as Location Property 58 (R,W)) * Not saved in EEPROM, this info will be lost after a power loss.
Long Screen Message	CSV	2	String of printable characters. (Same as Description Property 28 (R,W)) * Not saved in EEPROM, this info will be lost after a power loss.

PROPERTY VALUE RANGE RESTRICTIONS FOR PG OBJECTS

Object Name	Object Type	Instance	Parameters
Lua Program 1	PG	1	Lua program code is recorded in the description field
Lua Program 2	PG	2	Lua program code is recorded in the description field
Lua Program 3	PG	3	Lua program code is recorded in the description field
Lua Program 4	PG	4	Lua program code is recorded in the description field
Lua Program 5	PG	5	Lua program code is recorded in the description field
Lua Program 6	PG	6	Lua program code is recorded in the description field
Lua Program 7	PG	7	Lua program code is recorded in the description field
Lua Program 8	PG	8	Lua program code is recorded in the description field
Lua Program 9	PG	9	Lua program code is recorded in the description field
Lua Program 10	PG	10	Lua program code is recorded in the description field

PROPERTY VALUE RANGE RESTRICTIONS FOR SCH / CAL OBJECTS

Object Name	Object Type	Instance	Parameters
Occupancy Schedule	SCH	1	7 days of the week, 3 occupied setpoint times & 3 unoccupied setpoint times alternating in fixed order.
Occupancy Calendar	CAL	1	Date, Range of dates, Weekend

INTEGRATION – GLOBAL COMMANDS

The following figure shows which objects from the controller can be monitored and controlled from the BAS front-end.

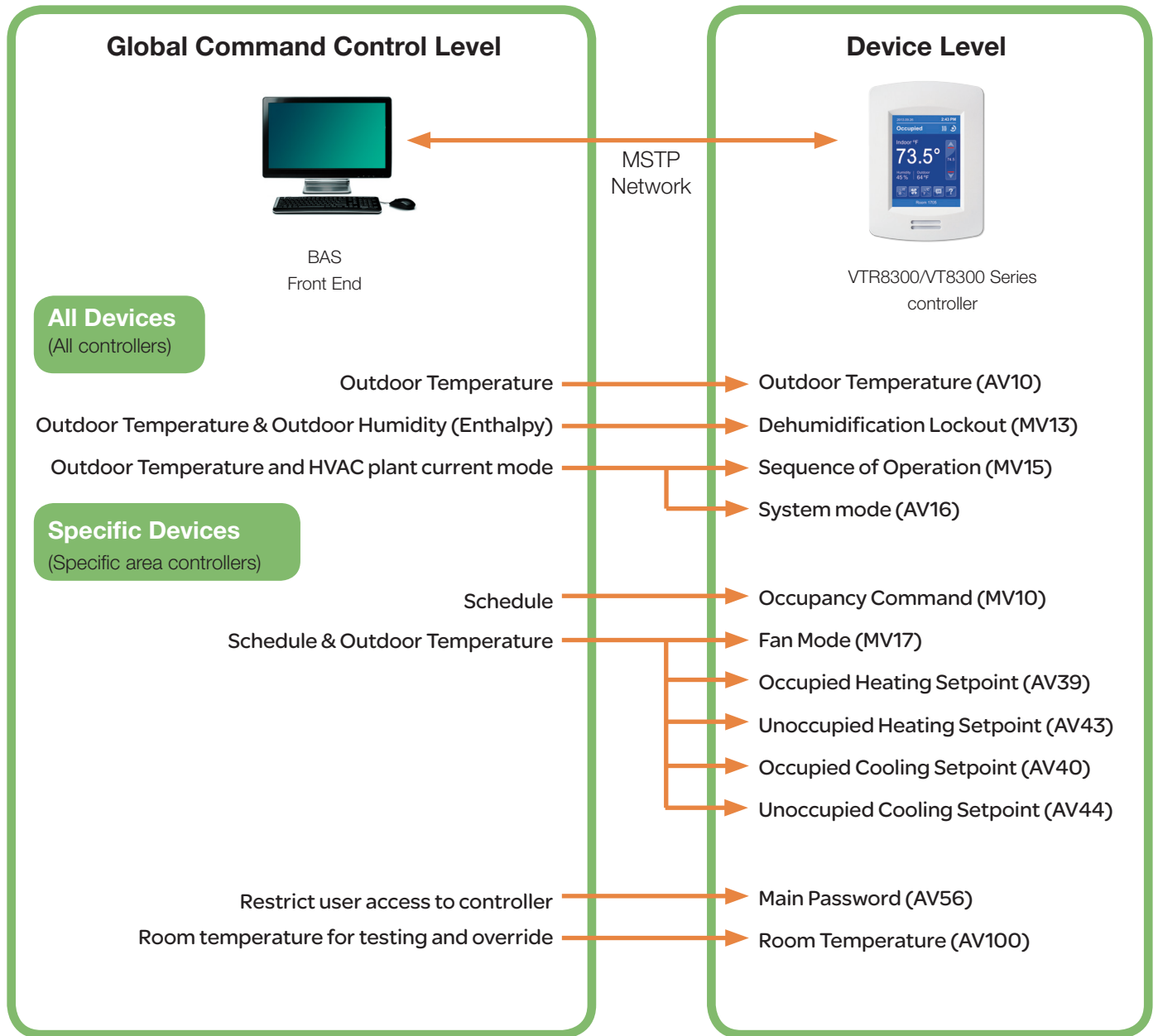

Figure 1: Global commands from a BAS front-end to a typical VT83xx series controller

Note: For information about integrating ZigBee wireless sensors with BACnet, refer to the ZigBee wireless sensor installation guide "Pairing VT8000 Series Room Controllers with ZigBee Sensors"

VTR8300/VT8300 INTEGRATION – GRAPHICAL USER INTERFACE OBJECTS

Objects typically used in a GUI:

- Room Temperature (AV100)
- Occupied and Unoccupied Heat Setpoints (AV 39 and AV43)
- Occupied and Unoccupied Cool Setpoints (AV 40 and AV44)
- Outdoor Temperature (AV101)
- Supply Temperature (AI102, if available)
- Occupancy Command (MV10)
- System Mode (MV16)
- Heating Output (BO 94)
- Cooling Output (BO93)
- PI Heating Demand (AO21)
- PI Cooling Demand (AO22)
- Window Alarm (BI 35)
- Filter Alarm (BI 36)
- Service Alarm (BI 37)

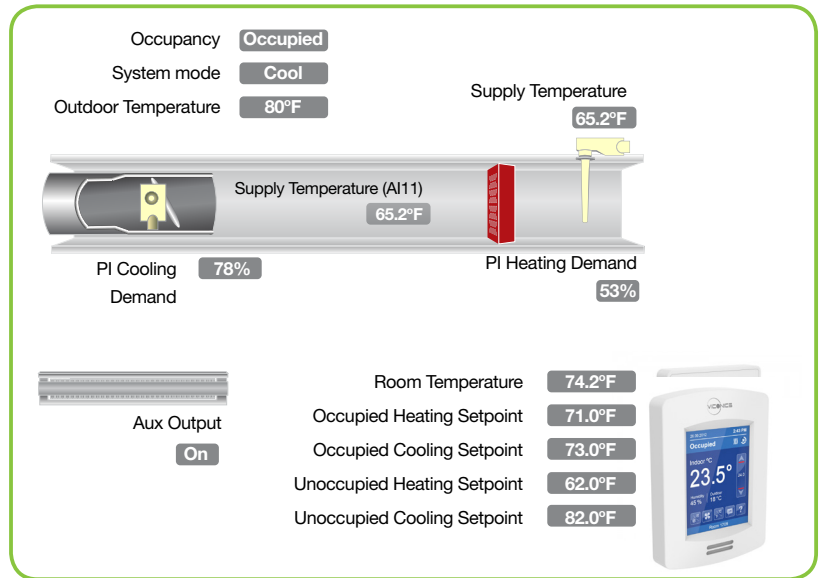

Figure-1 GUI Example - VTR8300

VTR8300/VT8300 INTEGRATION – GRAPHICAL USER INTERFACE OBJECTS

The following objects should be used in a GUI:

- Room Temperature (AV100)
- Occupied and Unoccupied Heat Setpoints (AV 39 and AV43)
- Occupied and Unoccupied Cool Setpoints (AV 40 and AV44)
- Room Humidity (AV103, if available)
- Room Humidity Setpoint (MV 70, if available)
- Outdoor Temperature (AV101)
- Supply Temperature (AV102, if available)
- Occupancy Command (MV10)
- System Mode (MV16)
- Fan Mode (MV17)
- Heating Output (BO 94)
- Cooling Output (BO93)
- PI Heating Demand (AO21)
- PI Cooling Demand (AO22)
- Window Alarm (BI 35)
- Filter Alarm (BI 36)
- Service Alarm (BI 37)

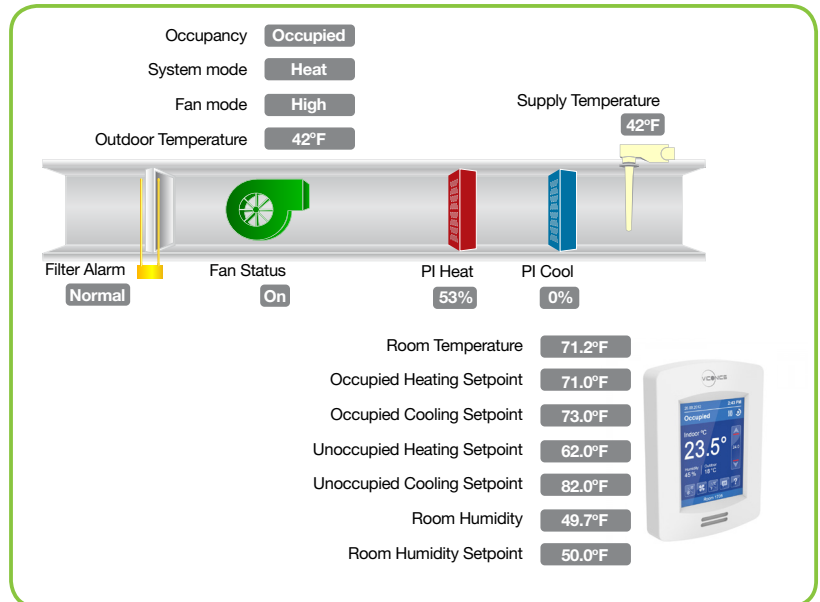

Figure-2 GUI Example - VTR8300

CONFIGURATION OBJECTS

If your BAS allows you to remove objects, Viconics recommends removing all configuration objects once your setup is complete. This prevents unnecessary network polling and traffic.

WIRING GUIDE

Overview

Viconics uses EIA-485 as the physical layer between their devices and supervisory controllers. A "Device" represents any product with an active EIA-485 network connection, including Viconics and non-Viconics controllers.

A summary of network specifications are listed below.

Summary Specifications

Parameter	Details
Media	Twisted pair 18 AWG, 22 AWG, or 24 AWG (shielded recommended)
Characteristic Impedance	100-130 ohms
Distributed capacitance	Less than 100 pF per meter (30 pF per foot)
Maximum length per segment	1200 meters (4000 feet) Note: 18 AWG cable
Polarity	Polarity sensitive
Multi-drop	Daisy-chain (no T connections)
Terminations	<ol style="list-style-type: none"> 1. Devices are installed at both ends of the MS/TP network: 120 Ohms resistor should be installed at each end. 2. A device is installed at one end of the MS/TP network and a third-party device is installed at the other end. Install an End-Of-Line resistor value that matches the third-party device instruction regarding the End-Of-Line resistors. 3. Third-party devices are installed at both ends of the MS/TP network. Follow the third-party device instructions regarding the End-Of-Line resistors.
Network bias resistors	510 ohms per wire (maximum two sets per segment)
Maximum number of nodes per segment	64 (Viconics devices only)
Maximum number of nodes per network	128
Baud rate	9600, 19200, 38400, 57600, 76800, 115200 (Auto detect)

Table : Summary of Specifications for a Viconics EIA-485 Network

WIRING GUIDE

Cable Type

Viconics recommends the use of balanced 22-24 AWG twisted pair with a characteristic impedance of 100-130 ohms and capacitance of 30 pF/ft or lower. A braided shield is also recommended.

Impedance

A value based on the inherent conductance, resistance, capacitance, and inductance that represent the impedance of an infinitely long cable. The nominal impedance of the cable should be between 100 ohms and 120 ohms. Using 120 ohms results in a lighter load on the network.

Capacitance (pF/ft)

The amount of equivalent capacitive load of the cable (per foot basis). One factor limiting total cable length is the capacitive load. Systems with long lengths benefit from using low capacitance cable (17pF/ft or lower).

NETWORK CONFIGURATION

EIA-485 networks use a daisy chain configuration. A daisy chain has only one main cable and every network device is connected directly along its path.

Figure 3 illustrates two improper network configurations and the proper daisy chain configuration.

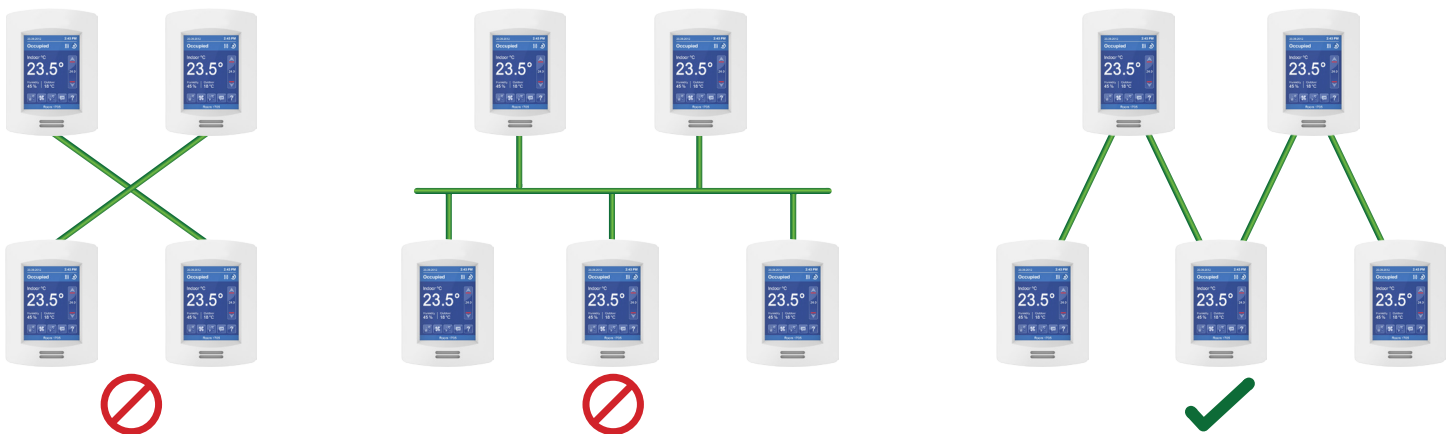

Figure 3 : Three different network configurations: star, bus, and daisy chain. Only the daisy chain configuration is correct for an EIA-485 network

Other methods of wiring an EIA-485 network may give unreliable and unpredictable results. There are no troubleshooting methods for these types of networks. Site experimentation may be required with no guarantee of success. As a result, Viconics only supports daisy chain configurations.

Recommended Maximum Number of Devices

For reasons of network performance, a maximum of 64 nodes is recommended on a single daisy-chain segment. A node is defined as any device (panel, zone, or Repeater) connected to the RS485 network. Terminators do not count as a node.

Add the following to determine the number of nodes on a network:

- One node for each device, including main panels
- One node for each repeater on the chain

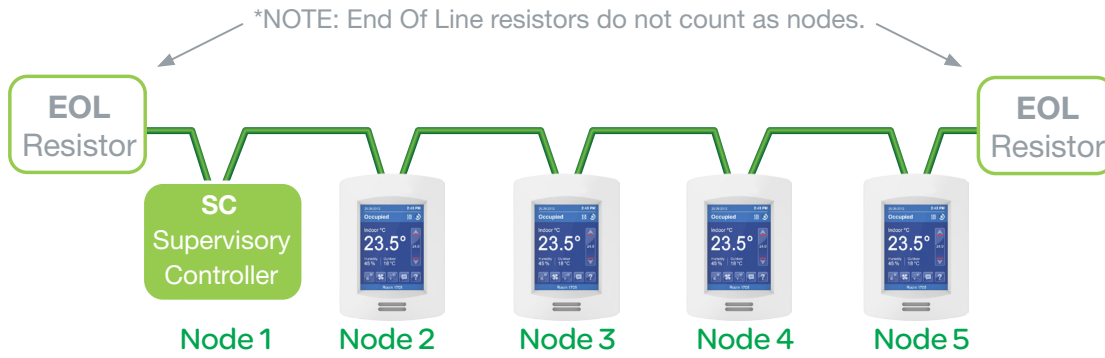

Figure 4: Example Network - 5 Nodes

Figure 4 shows one node for the main SC panel and 4 for the controllers, for a total of 5 nodes. If more than 64 devices are needed on the network, install repeaters to create additional network segments. However, the BACnet MS/TP protocol may exhibit slow performance on large networks with more than 64 total nodes.

Maximum Cable Length

The maximum length of a chain is related to its transmission speed. The longer the chain, the slower the speed. Using proper cable, the maximum length of an EIA-485 daisy chain is 4000-ft (1200 m). This only works reliably for data rates up to 100,000 bps. Viconics' maximum data rate is 76,800 bps. If you require a maximum network length of more than 4000 feet, repeaters are required to extend the network.

EIA-485 Repeaters

If you have more than 64 devices, or require a maximum network length of more than 4000 feet, repeaters are required to extend the network. Note that long networks or networks with more than 64 nodes may experience slow performance due to limitations of the BACnet MS/TP protocol.



Figure-5 Correct Repeater Use in an EIA-485 Network

The ideal configuration is to daisy chain the repeaters to the main panel. From each of these repeaters, a separate daisy chain branches off. Figure 5 demonstrates a valid use of repeaters in an EIA-485 network.

Do not install repeaters in series as this may result in network reliability problems. Incorrect use of a repeater in an EIA-485 network is illustrated in Figure 6.



Figure-6 Incorrect Repeater Use in an EIA-485 Network

End Of Line (EOL) Resistors

A MS/TP network must be properly terminated. For daisy chain configurations, you must install an EOL resistor at each end of the daisy chain. Depending on your MSTP network configuration, the resistance value of the EOL resistor may change.

- If Viconics's devices are installed at both ends of the MSTP network, a 120 Ohm resistor should be installed at each end.
- If a Viconics device is installed at one end of the MSTP network and a 3rd party device is installed at the other end, make sure you install an EOL resistor value that matches the 3rd party devices instructions regarding its EOL resistor value, and install a 120 Ohm resistor at the Viconics device end.
- If 3rd party devices are installed at both ends of the MSTP network, both must use EOL resistors with values matching the those described in the instructions for the devices.

Network Adapter

BACnet® Communication Wiring (if applicable)



Figure-7 MS/TP Connections

The polarity of the connection to the cable is important. From one module to the other it is important that the same colored wire be connected to “plus” or “+” and the other colored wire be connected to the “minus” or “-“. Figure 7 shows the proper MS/TP connections.

NOTE: The Ref terminal should NEVER be used to wire shields. The 2 shields from each feed of the network connection to a controller should be wired together in the back of the controller and properly protected to prevent any accidental connection to the ground.

The joined shield connection should then be grounded at a SINGLE point on the whole segment. More than one ground connection to a shielded wire may induce ground loop noises and affect communication.

DEFAULT DEVICE NAME AND ID

Default Device Name set to Model number – MAC where:

- MAC is the current MAC address of the device.
- Model number is Viconics part number.

The device name upgrades as soon as there is a change to the device MAC address.

The Device Name and Device ID properties are writable. Both properties can be renamed from any BACnet® network management tool as long as the tool itself can write to these properties.

VTR8300/VT8300 Models

Default Device ID is set to: 83000 + MAC where MAC is the current MAC address of the device.

The device ID upgrades as soon as there is a change to the device's MAC. For example, when a VTR8300 controller with a MAC address of 63 is connected to a network, its default Device ID is 83063.

INTEGRATING VICONICS DEVICES ON A BACNET MS/TP NETWORK

Before doing any BACnet® integration, make sure you refer to a Viconics PICS document (Protocol Implementation Conformance Statement). The PICS document lists all the BACnet® Services and Object types supported by a device. You can find the document at www.viconics.com.

Viconics devices do not support the COV service. COV reporting allows an object to send out notices when its Present-Value property is incremented by a pre-defined value. Since this is not supported at Viconics, special attention should be given to the polling time settings at the Supervisory Controller and Workstation level when using a graphic interface or an application program to read or write to a Viconics object.

Graphical Interfaces

A graphic interface might poll all data linked to the graphic page on a COV basis. If the third-party device does not support COV, the graphical interface relies on a pre-configured polling interval, which is usually in hundredths of milliseconds. Any device containing a monitored object could be subject to network traffic congestion if such a polling interval is used. Viconics strongly recommends a polling interval of 5 seconds (minimum) for any graphical interface. This becomes even more critical in graphics where a single representation might poll many devices. If the proper poll rate is not respected, devices may be reported offline by certain front-ends by saturating the traffic handling capacity of BACnet® MS/TP without COV subscription.

Free Programmed Object or Loops

Read and write MS/TP data on an "If Once" basis or a "Do Every Loop" basis instead of reading or writing to a third-party device's object directly in the program. Otherwise, any read or write request occurs at the Supervisory Controller's program scan rate, which may be in hundredths of milliseconds. This can bog down a network as single commands can be sent to all ASC devices down the MS/TP trunks every hundredths of milliseconds

Programs writing to the devices should have a structure similar to the following:

If Once Schedule = On then		Do Every 5min
MV10 = Occupied		If Schedule = On Then
End If		MV10= Occupied
If Once Schedule = Off Then	OR	Else
MV10 = Unoccupied		MV10 = Unoccupied
End If		End If
		End Do

Retries and Timeouts

In BACnet® integration, you should note the device object of the Supervisory Controller and Operator's Workstation. This object contains the two following required properties:

- 1) Retry Timeout
- 2) Number of APDU Retries

The Retry Timeout specifies the time between re-transmissions if the acknowledgement is not received. Increasing this value may help if you are experiencing problems with controllers dropping off line.

The Number of APDU Retries specifies the number of times unsuccessful transmissions are repeated. If the receiving controller has not received the transmission successfully after this many attempts, no further attempts will be made.

For example, if one of the controllers does not reply to a Supervisory Controller (SC) request, and the SC's Retry Timeout is set to 2000 milliseconds and the Number of APDU Retries is set to 1 (SC level), the SC sends one other request 2 seconds later. If the MS/TP device does not reply, it is considered off line by the workstation.

Having a Retry Timeout value of 10450 milliseconds and a Number of APDU Retries property set to 3 at the SC level may prevent the device from dropping off line. These properties should also be changed at the workstation level since the workstation issues requests to any MS/TP devices when the graphics are used.

Writing and Binding Behaviour

Refer to the proper section as per the table below for BACnet write command behaviour for specific objects and functionality.

- Green = proper write binding method
- Orange = correct write binding method with behaviour changes on the user HMI
- Red = application locking write binding method

Object type	Relinquish Default	Priority Array 4-16	Priority Array 1-3
AI's, BI's & MI's	Note A)	Note A)	Note A)
Configuration Properties	Note B)	Note C)	Note C1)
User HMI objects	Note B)	Note C)	Note C1)
Status objects	Note D)	Note E)	Note E1)
Physical hardware output objects	Note D)	Note F)	Note F1)

Note A) AI's, BI's & MI's.

Object examples in this category: AI2 / Light Sensor Level, BI29 / UI16 Status, MI33 / Effective Occupancy.

All input objects are read only and cannot be written to independently of the priority array used. These types of points are typically used for statuses and external logic functions.

Note B) Configuration Properties and User HMI objects.

Object examples in the configuration property category: AV57 / User Password, BV6 / Force High Level Backlight, MV2 / HMI color.

Object examples in the User HMI category: AV40 / Occupied Cool Setpoint, MV16 / System Mode, MV17 / Fan Mode.

Writing and binding to the relinquish default property is the preferred method to use when setting up network logic using the configuration properties and user HMI objects.

When writing and binding to the relinquish default, the control will store and archive the new written present value in flash over the network. As soon as the new present value is received, the controller will use this new present value in all its internal control logics and functions.

When writing and binding to the relinquish default, the controller internal control logics and functions are **NOT** by-passed, and the controller will still operate normally.

When writing and binding to the relinquish default, a user can still change user HMI values and an installer can still change configuration properties. In this case, the present value used by the controller internal control logics and functions is the last one received. Either the network present value or a value changed locally at the controller HMI.

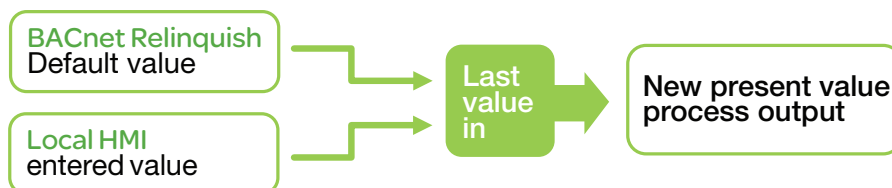

Note C) Configuration Properties and User HMI objects.

Writing and binding to the priority arrays 4 to 16 property is a method to use **IF** the required intent is to lock the local HMI and prevent local adjustments made by the user HMI values or the configuration property values. If preventing the local user from accessing or tampering with the local HMI is the goal there are other simpler and more elegant ways to do so:

- Proper selection of the user experience of the local HMI. AV2 / User HMI can tailor the user screen to properly present to the user the only local adjustments allowed. In total 12 different HMI user screen options are available. Locking the object by writing to array 4 to 16 is not required.
- AV56 / Main Password will prevent unauthorized installers from tampering with the configuration properties. Locking the object by writing to array 4 to 16 is not required.
- AV57 / User Password will prevent unauthorized users from tampering with the user HMI value. Locking the object by writing to array 4 to 16 is not required.

When writing and binding to the priority array 4 to 16, the control will **NOT** store and archive to flash memory and will simply use it in RAM. As soon as the new present value is received in priority arrays 4 to 16, the controller will use this new present value in all its internal control logics and functions.

When writing and binding to the priority array 4 to 16, the controller internal control logics and functions **ARE** bypassed, and the controller will **NOT** operate with its own present values, but will be forced to use the last write commands received on priority arrays 4 to 16 for its built-in internal control logics and functions. **HOWEVER**, since these present values are only stored in RAM and not in flash, if a power reset occurs, the override type function will be lost and the controller will start to operate using the relinquish default value. If the override type function is required, a new write command to priority arrays 4 to 16 is needed.

The controller fully supports native and BACnet compliant priority array 1 to 16 write commands. This simply means that a write value at level 4 has a higher authority than a write at level 9.

When writing and binding to priority array 4 to 16, a user **cannot** change user HMI values and an installer **cannot** change configuration properties. In this case, the present value used by the controller internal control logics and functions is the last write command received at priority array 4 to 16.

You can easily identify an overridden point at the controller in either configuration view, the setpoint view, the service view or the test outputs view. The point will be highlighted in **RED** indicating a write command to priority array 4 to 16.

The **ONLY** way to release the override due to the use of writing to priority array 4 to 16 is to send a **write NULL** command to the proper priority array currently locking the controller.

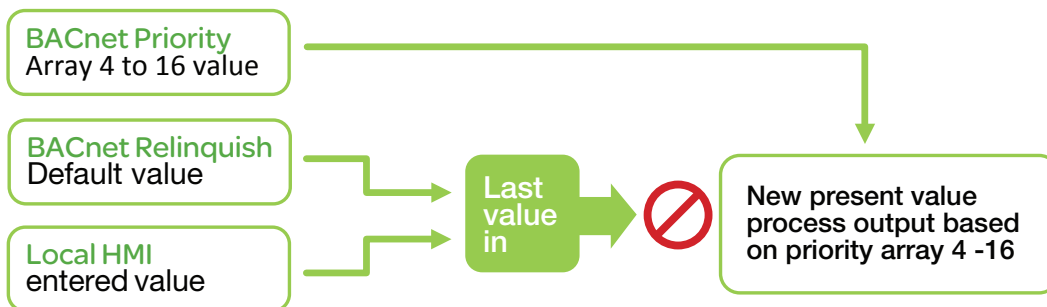
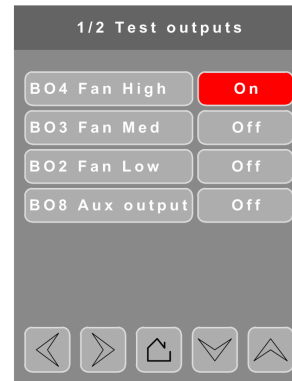

Note C1) Configuration Properties and User HMI objects.

The behaviour is similar to the behaviour described in NOTE C with the following exceptions and changes

When writing and binding to the priority array 1 to 3, the controller **WILL** store and archive to flash memory. As soon as the new present value is received in priority array 1 to 3, the controller will use this new present value in all its internal control logics and functions.

When writing and binding to the priority array 1 to 3, the controller internal control logics and functions **ARE** bypassed the same way they are when writing to priority array 4 to 16. The controller will **NOT** operate with its own present values, but will be forced to use the last write commands received on priority array 1 to 3 for its built-in internal control logics and functions. **HOWEVER**, since writing to priority array 1 to 3 will store the value in flash memory, if a power reset occurs, the override type function **will be maintained** and the controller will start to operate right away using the last value written to priority array 1 to 3.

The **ONLY** way to release the override due to the use of writing to priority array 1 to 3 is to send a **write NULL** command to the proper priority array currently locking the controller. Only then will the controller start using the relinquish default value and allow the user or installer to change values.

Note D) Status objects and Physical hardware output objects.

No override functions are effective when writing or binding to the relinquish default property of status objects and physical hardware output objects. When writing to the relinquish default property, the internal program is not bypassed and still has priority over the write command on the relinquish default property.

The internal program constantly writes internally to the same location used by the relinquish default property hence a single BACnet write at relinquish default has no effect on status objects and physical hardware output objects.

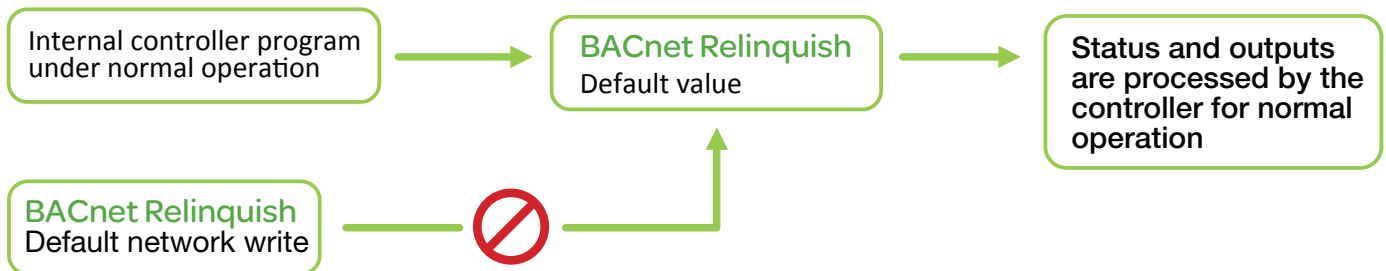

Note E) Status objects.

Object examples in this category: BV36 / Filter Alarm, AV21 / PI Heating Demand. All status objects are writable.

Writing and binding to the priority array 4 to 16 property is a method to use **IF** the requirement is to lock the controller program and prevent statuses from being flagged based on the internal operation of the controller application programming.

When writing and binding to the priority array 4 to 16, the control will **NOT** store and archive to flash memory and will simply use it in RAM. As soon as the new present value is received in priority array 4 to 16, the controller will use this new present value in all its internal control logics and functions.

When writing and binding to the priority array 4 to 16, the controller internal control logics and functions **ARE** bypassed, and the controller will **NOT** operate with its own present values, but will be forced to use the last write commands received on priority array 4 to 16 for its built-in internal control logics and functions. **HOWEVER**, since these present values are only stored in RAM and not in flash, if a power reset occurs, the override type function will be lost and the controller will start to operate using the relinquish default value. If the override type function is required, a new write command to priority array 4 to 16 is needed.

The controller fully supports native and BACnet compliant priority array 1 to 16 write commands. This simply means that a write value at level 4 has a higher authority than a write at level 9.

When writing and binding to priority array 4 to 16, you locally identify if an override is effective on a status object using the service view. The point will be highlighted in **RED** indicating a write command to priority array 4 to 16. In this case, the present value used by the controller internal control logics is by-passed and the value displayed and used is the last write command received at priority array 4-16.

The **ONLY** way to release the override due to the use of writing to priority array 4 to 16 is to send a **write NULL** command to the proper priority array currently locking the controller.

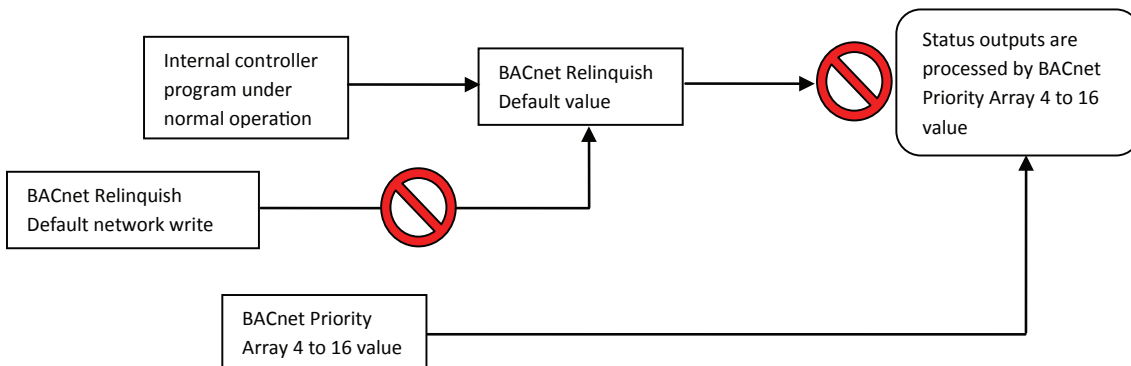
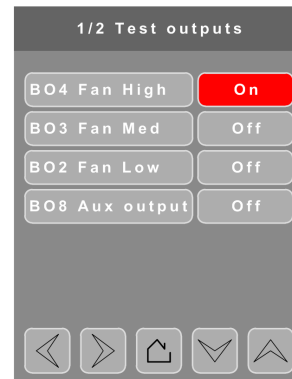

Note E1) Status objects.

Object examples in this category: BV36 / Filter Alarm, AV21 / PI Heating Demand. All status objects are writable.

The behaviour is similar to the behaviour described in NOTE E with the following exceptions and changes

When writing and binding to the priority array 1 to 3, the controller **WILL** store and archive to flash memory. As soon as the new present value is received in priority array 1 to 3, the controller will use this new present value in all its internal control logics and functions.

When writing and binding to the priority array 1 to 3, the controller internal control logics and functions **ARE** bypassed the same way they are when writing to priority array 4 to 16. The controller will **NOT** operate with its own present values, but will be forced to use the last write commands received on priority array 1 to 3 for its built-in internal control logics and functions. **HOWEVER**, since writing to priority array 1 to 3 will store the value in flash memory, if a power reset occurs, the override type function will be maintained and the controller will start to operate right away using the last value written to priority array 1 to 3.

The **ONLY** way to release the override due to the use of writing to priority array 1 to 3 is to send a **write NULL** command to the proper priority array currently locking the controller. Only then will the controller start using the relinquish default value and allow the user or installer to change values.

Note F) Physical hardware output objects.

Object examples in this category: BO95 / BO4 High Speed fan, AO123 / UO11 Analog Status. All physical hardware output objects are writable. **CAUTION NEEDS TO BE EXERCISED** since bypassing the internal control functions of the controller **CAN RESULT** in damage to the equipment.

Writing and binding to the priority array 4 to 16 property is a method to use **IF** the requirement is to lock the controller program and prevent physical hardware output objects from being powered based on the internal operation of the controller application programming.

When writing and binding to the priority array 4 to 16, the control will **NOT** store and archive to flash memory and will simply use it in RAM. As soon as the new present value is received in priority array 4 to 16, the controller will use this new present value in all its internal control logics and functions.

When writing and binding to the priority array 4 to 16, the controller internal control logics and functions **ARE** bypassed, and the controller will **NOT** operate with its own present values, but will be forced to use the last write commands received on priority array 4 to 16 for its built-in internal control logics and functions. **HOWEVER**, since these present values are only stored in RAM and not in flash, if a power reset occurs, the override type function will be lost and the controller will start to operate using the relinquish default value. If the override type function is required, a new write command to priority array 4 to 16 is needed.

The controller fully supports native and BACnet compliant priority array 1 to 16 write commands. This simply means that a write value at level 4 has a higher authority than a write at level 9.

When writing and binding to priority array 4 to 16, you locally identify if an override is effective on a status object using the test output view or the service view. The point will be highlighted in **RED** indicating a write command to priority array 4 to 16. In this case, the present value used by the controller internal control logics is bypassed and the value displayed and used is the last write command received at priority array 4-16.

The **ONLY** way to release the override due to the use of writing to priority array 4 to 16 is to send a **write NULL** command to the proper priority array currently locking the controller.

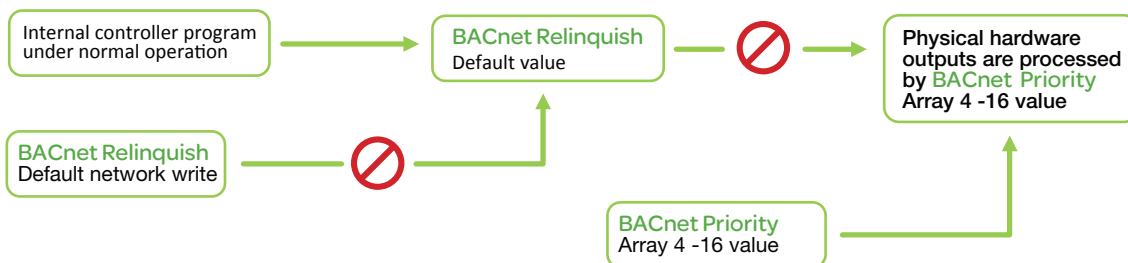
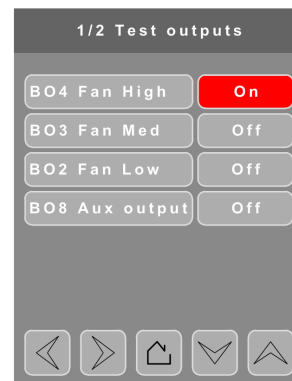

Note F1) Physical hardware output objects.

Object examples in this category: BO95 / BO4 High Speed fan, AO123 / UO11 Analog Status. All physical hardware output objects are writable. **CAUTION NEEDS TO BE EXERCISED** since bypassing the internal control functions of the controller **CAN RESULT** in damage to the equipment.

The behaviour is similar to the behaviour described in NOTE F with the following exceptions and changes

When writing and binding to the priority array 1 to 3, the controller **WILL** store and archive to flash memory. As soon as the new present value is received in priority array 1 to 3, the controller will use this new present value in all its internal control logics and functions.

When writing and binding to the priority array 1 to 3, the controller internal control logics and functions **ARE** bypassed the same way they are when writing to priority array 4 to 16. The controller will **NOT** operate with its own present values, but will be forced to use the last write commands received on priority array 1 to 3 for its built-in internal control logics and functions. **HOWEVER**, since writing to priority array 1 to 3 will store the value in flash, if a power reset occurs, the override type function **will be maintained** and the controller will start to operate right away using the last value written to priority array 1 to 3.

The **ONLY** way to release the override due to the use of writing to priority array 1 to 3 is to send a **write NULL** command to the proper priority array currently locking the controller. Only then will the controller start using the relinquish default value and allow the user or installer to change values.

General Notes on BACnet Writing and Binding Behaviour.

- If in doubt as to whether a point is overridden using BACnet priority array 1 to 16 or not, open the controller configuration menu, the service view or the test output view. An overridden point will appear in RED in the tables.
- ALL entries in priority array 1 to 16 MUST be set to “null” if normal operation using the internal control functions and factory application program is to be used.
- Reinitializing the controller to factory default directly from the configuration interface at the controller WILL release ANY and ALL write entries into priority array 1 to 16 on ALL objects.

Summary for Integrators

- AI's, BI's & MI's are not writable and are typically only used for status
- Configuration properties and user HMI objects
 - Write and bind to relinquish default if you want the local interface to still be able to modify these settings
 - Write and bind to priority array 4 to 16 if you desire to override the local application but not save that override after a power reset
 - Write and bind to priority array 1 to 3 if you desire to override the local application and save that override after a power reset
- Status objects and physical hardware output objects
 - Write and bind to relinquish default has no effect since the internal application program constantly overrides the last network command value
 - Write and bind to priority array 4 to 16 if you desire to override the local application but not save that override after a power reset
 - Write and bind to priority array 1 to 3 if you desire to override the local application and save that override after a power reset

TIPS AND THINGS YOU NEED TO KNOW

- Each controller is delivered from the factory with the default MAC address set at 254. At this value, the BACnet® communication is not active and the device does not participate in the token pass. To enable the BACnet® communication, set the local MAC address configuration property of the controller to any valid value from 0 to 127.
- After the initial configuration of your device and if your BAS allows you to remove objects, you should remove all configuration objects to prevent unnecessary polling of unused objects and to help speed up the network.
- In default mode of operation, the device automatically matches its baud rate to the baud rate of the network. Automatic baud rate detection occurs when the MS-TP communication port is initialized (on power up). If the network speed is changed, the device keeps listening at the previously detected speed for 10 minutes before resuming auto-baud. Re-powering the devices forces the auto-baud.
- If the device goes off line, the following bound controller parameters are released:
 - Room Temperature
 - Outdoor Temperature
 - Occupancy
- The BACnet® Data Link layer has two key parameters, the device object name and the device object ID. The device object name must be unique from any other BACnet® device object name on the BACnet® network (not just the MS-TP sub-network). The device object ID must be unique from any other BACnet® device object ID on the entire BACnet® network (not just the MS-TP sub-network).
- Time synchronization can be made through a network even if the controller does not support the full date. Therefore, the device cannot claim conformance to the Device Management – Time Synchronization - B (DM-TS-B) service. The device object does not have the Local_Time or Local_Date properties.
- Device Name and Device ID properties are writable in Viconics device objects. Both properties can be renamed from any BACnet® network management tool as long as the tool itself gives access to write to these properties.

TROUBLESHOOTING

Error / Fault	Possible Cause	Solution
Controller does not come online	Two or more controllers have the same MAC address.	Modify each duplicate address to a unique number.
	The MS-TP network has too many devices.	Do not exceed the maximum number of devices and maximum length allowed by the EIA-485 specifications.
	Too many devices were installed without any repeaters.	Repeaters must be installed
	The MS-TP cable runs are broken	Locate the break and correct the wiring.
	MS-TP connections at the module are reversed	Respect polarity of the wires on a MS-TP network.
	The controller does not have power	Apply power to the controller

APPENDIX A

Important notice to all Niagara integrators

For all intents and purposes, BO95 / BO 4 High Speed Fan Output is used on all examples below. Where BO95 is the object BACnet instance and BO 4 is the terminal location on the controller

Using native Niagara Set Command for an object

Typically when BACnet device objects are discovered under a BACnet device in Niagara, objects are proxied under the local server database using standard Niagara device and object management processes.

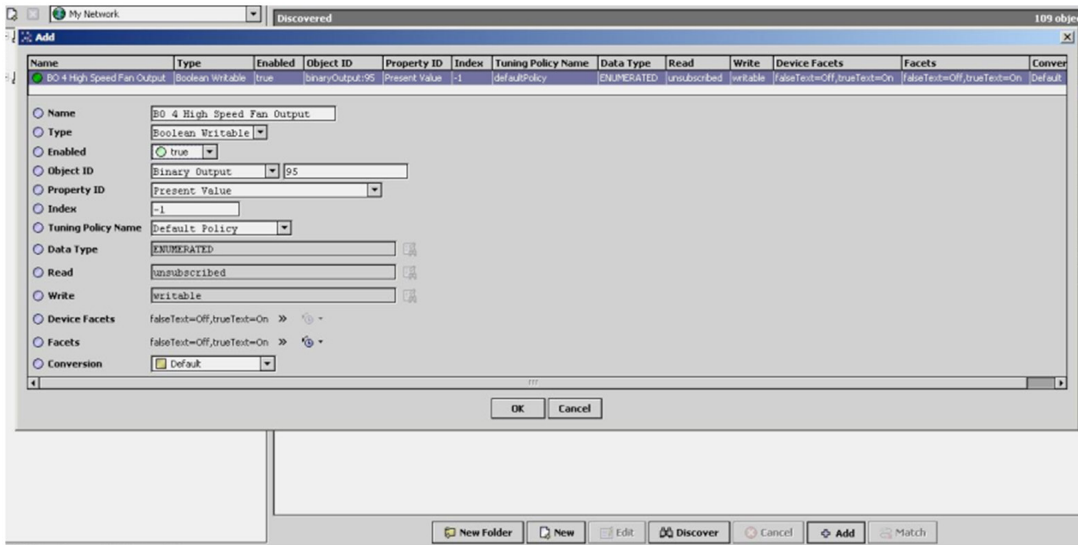

As such using the simple add object command, Niagara creates local proxy extensions of certain of the object properties including the BACnet object present value.

When using the “set” command under Niagara, the local server issues a BACnet write command to the controller **without** specifying any specific priority array from 1 to 16. As per the BACnet standard, when a controller receives an unspecified write command, the controller automatically assigns it to priority array level 16.

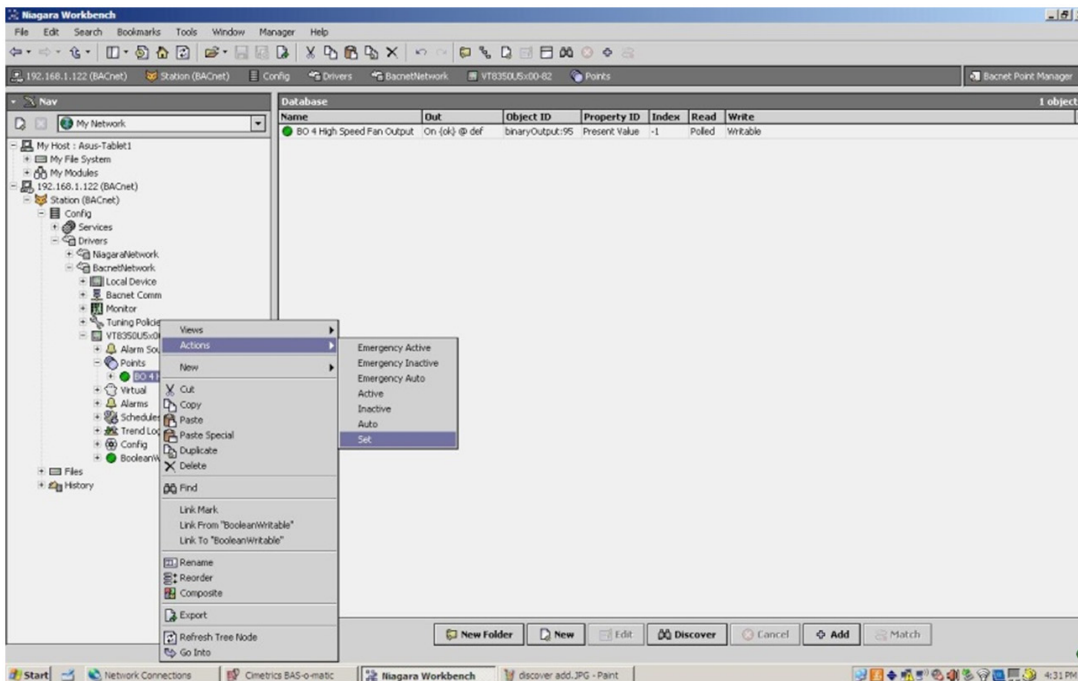

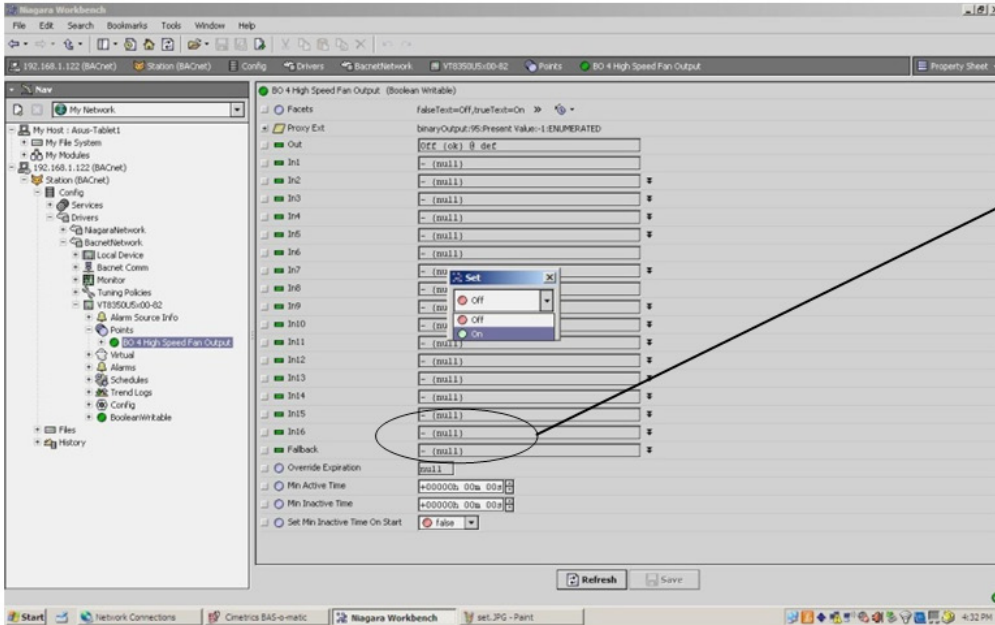

Array 16 shows NULL after a SET command

As such, the controller now has an entry in priority array 16 of an object which effectively **“overrides”** it and **by-passes** the local control application program.

The know issue with this is that by default, Niagara does not poll or update any of the priority arrays of an object and it is NOT reflected under the proxied object property sheet.

So although you do see the real present value of the object under present value “Out” extension of the object, the displayed priority array 16 “In16” shows a value of NULL. But in effect, it is not NULL.

Viewing if a BACnet array 1 to 16 is actually being used

The only way to positively confirm if a point has an entry in any of the 16 priority array levels is to use the Niagara BACnet “Config” view. Simply open the view and add the objects as needed.

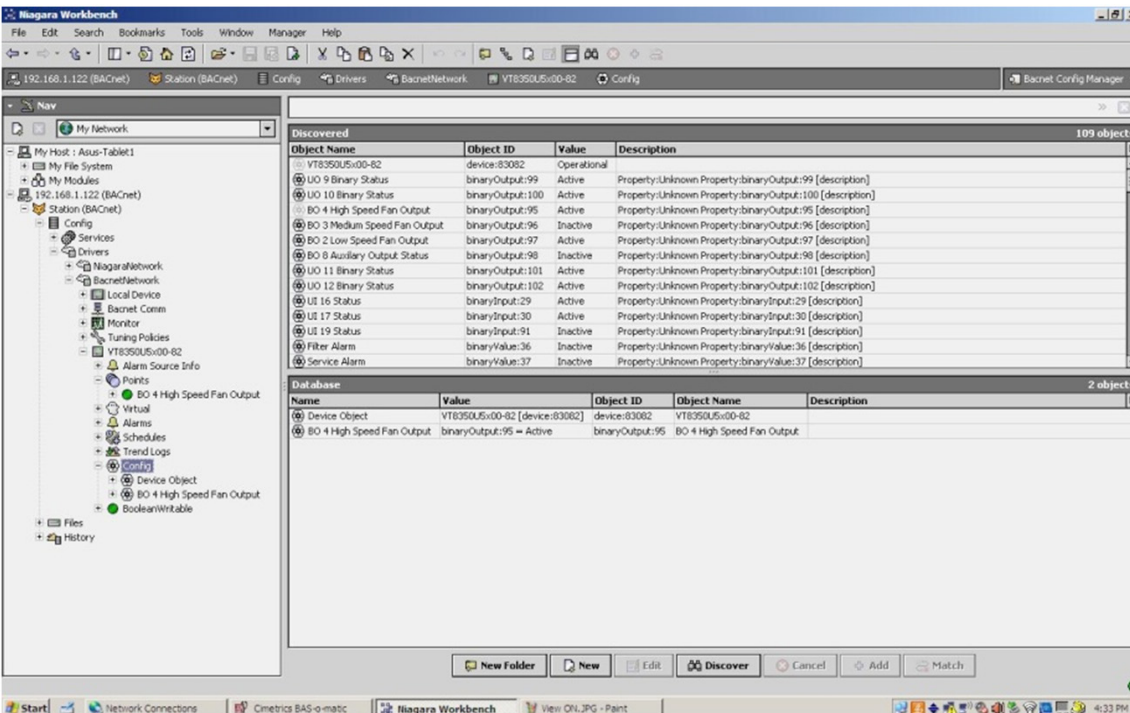

Now to confirm if there is an entry, simply view the property sheet of the BACnet object.

In this view you will confirm an entry at level 16 or any other priority array level.

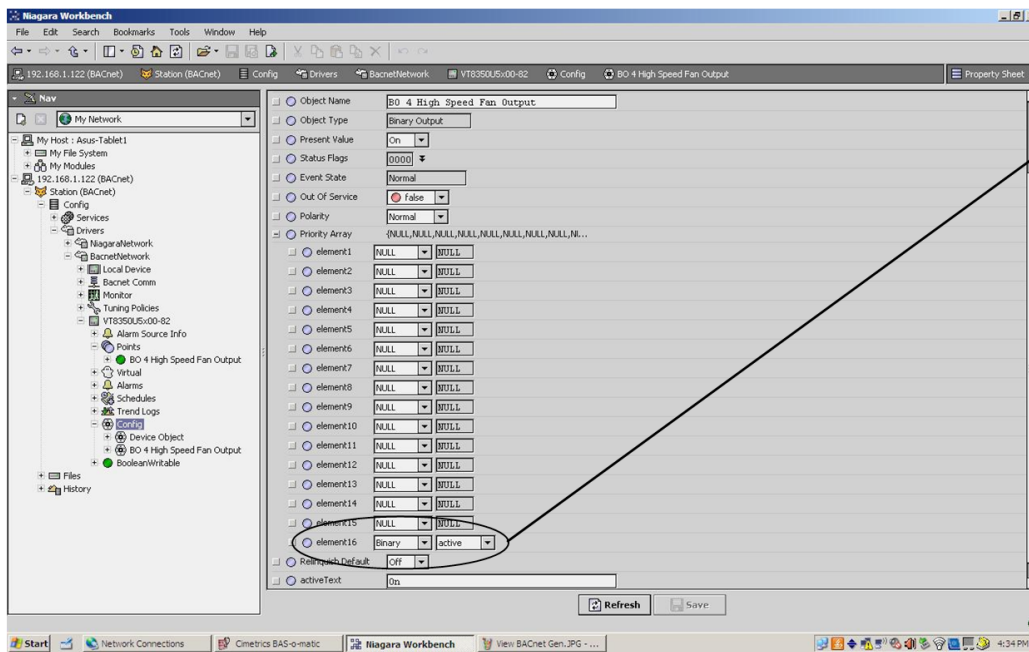

BACnet Array 16 shows the real controller value overriding the point after a set command

If the point was overridden by accident and the normal controller operation is required and desired, simply set the overridden priority array to NULL to resume the controller normal operation under the relinquish default property value.

Binding to a point using the Fallback

Caution need to be taken when binding objects to specific server logic for central control and applications. The same cautions that apply to the “set” command apply to the binding of a point using the Niagara “fallback” proxy extension.

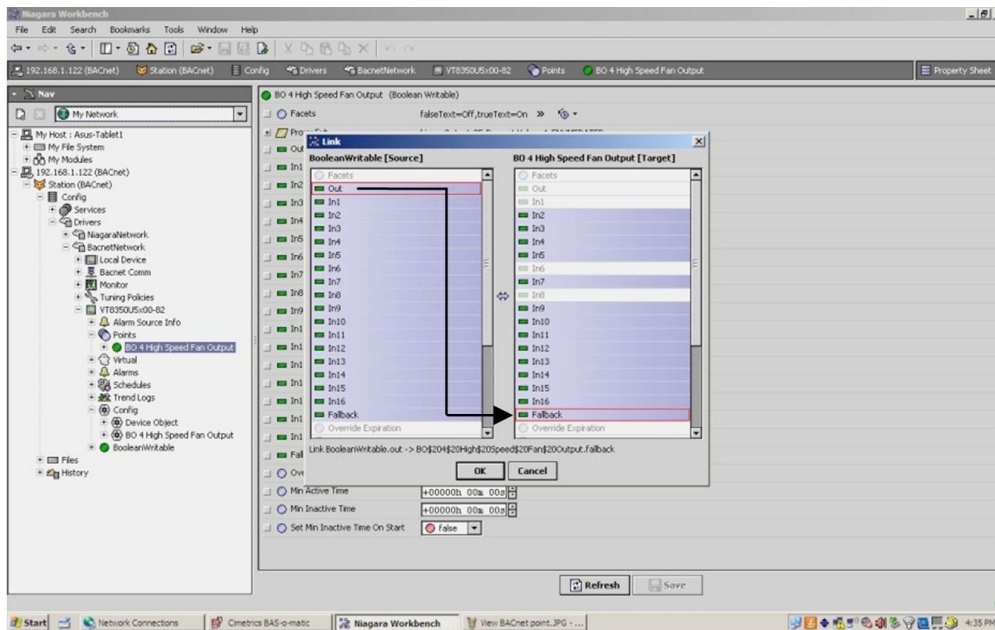

Binding a logic block or function to the “fallback” sets the same behaviour as using the Niagara “set” command. The local server issues a BACnet write command to the controller **without** specifying any

specific priority array from 1 to 16. As per the BACnet standard, when a controller receives an unspecified write command, the controller automatically assigns it to priority array level 16.

As such, the controller now has an entry in priority array 16 of an object which effectively **overrides** it and **by-passes** the local control application program.

If the intent of the central logic block or sequence is simply to reset local values and still allow local users to change certain settings (such as setpoints and system mode for example) then the easiest way is to bind the logic block to the BACnet relinquish default property value as described below.

Adding the relinquish default object property for binding

In the Niagara point manager under the device, click on the plus (+) icon to expand all the options and properties of the desired object.

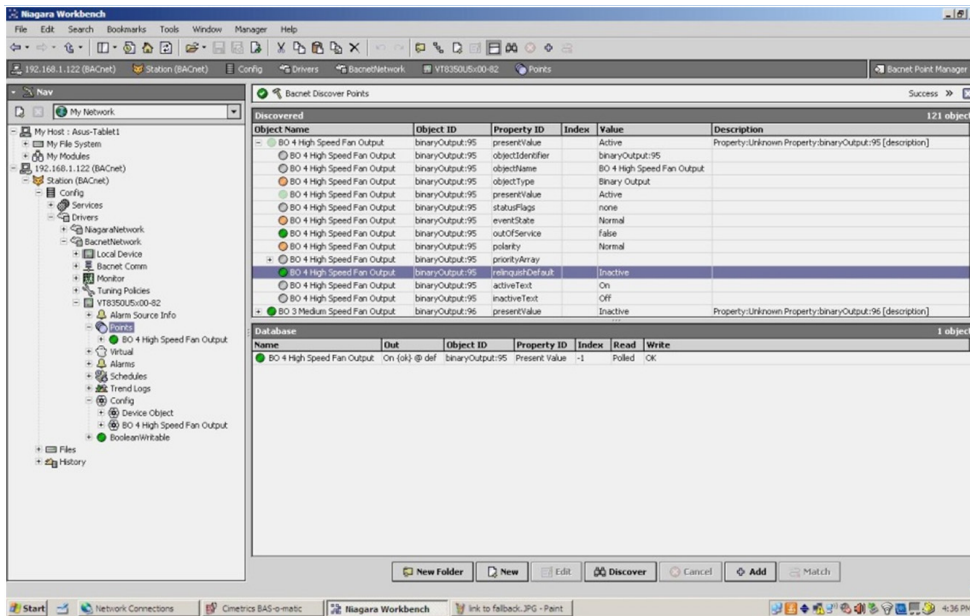

Locate the relinquish default property value and add it to the local server database of proxied objects.

Make sure it is added as a writable object and that it is enabled.

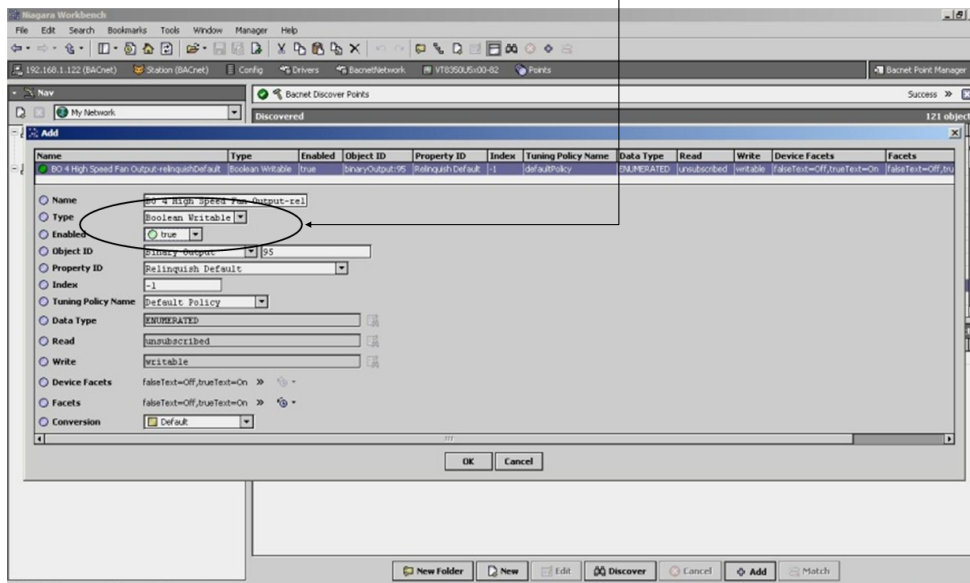

Now when binding your logic block simply point to the relinquish default property of an object at the “fallback” value. This will directly issue the write command to the relinquish default property value insuring you are not locking down the application at priority array 16.

